



SMC12

TECHNICAL DATA

Flow rate maximum: up to 540 m³/h

Head up to: 310 m

Maximum immersion depth: depending on the motor

Type of pumped liquid: clean, free from solid or abrasive substances, non-viscous, non-aggressive, non-crystallized and chemically neutral.

Maximum sand quantity: 80 g/m³

Liquid temperature range: from 0°C to + 30°C

Flanges, thread:

7" with counter flange to be welded onto the pipeline supplied as standard

Pump maximum diameter: 298 mm

Impeller/s material: pressed AISI 316 stainless steel

Maximum number of starts: depending on the motor

Protection class: IP 68

Motor insulation class: depending on the motor

Single phase power input: not available

Three phase power input: 3x230 V 50 Hz / 3x400 V 50 Hz

Power cable (m) and plug: depending on the motor (all the motor are without the power plug)

Possible type of installation: fixed in vertical position. Horizontal installation permitted by removing the non-return valve and installing a cooling jacket (check the applicability of the motor for horizontal use in the dedicated section)

12" multi-impeller semi-axial submersible pump with cast iron stage bodies treated with anti-corrosion cataphoresis paint coating. Pumps designed for pressurization, drawing water from the subsoil in civil and commercial applications and use in water in irrigation systems, also in the agricultural sector. The pump is ideal for installation in wells (of at least 12"). The pump is compliant with DM174 for use with water for human consumption.

CONSTRUCTION FEATURES OF THE PUMP

Cast iron pump body treated with cataphoresis paint coating and dynamically balanced impellers in microcast AISI 316 stainless steel coupled on the shaft with pull tab. Shaft guided with coaxial bush bearings and fully protected with bushes. Integrated non-return valve to reduce localized pressure drops. Stainless steel filter applied to the suction outlet to prevent the entry of dissolved solid bodies. Different types of impeller are available to guarantee the best efficiency at different flow rates and models up to 5 impellers to cover a wide range of heads.

CONSTRUCTION FEATURES OF THE MOTOR

Coupling with motors from 8" to 12" depending on the power required by the hydraulic system:

- TR8: 8" submersible rewindable motor
- TR10: 10" submersible rewindable motor
- TR12: 12" submersible rewindable motor

For operation with the variable frequency drive, refer to the specifications of the coupled motor.

PERFORMANCE RANGE

The performance curves are based on the kinematic viscosity values = 1 mm²/s and density equal to 1000 kg/m³. Curve tolerance according to ISO 9906.

GRAPHIC SELECTION TABLE

50 Hz - 2900 r.p.m.

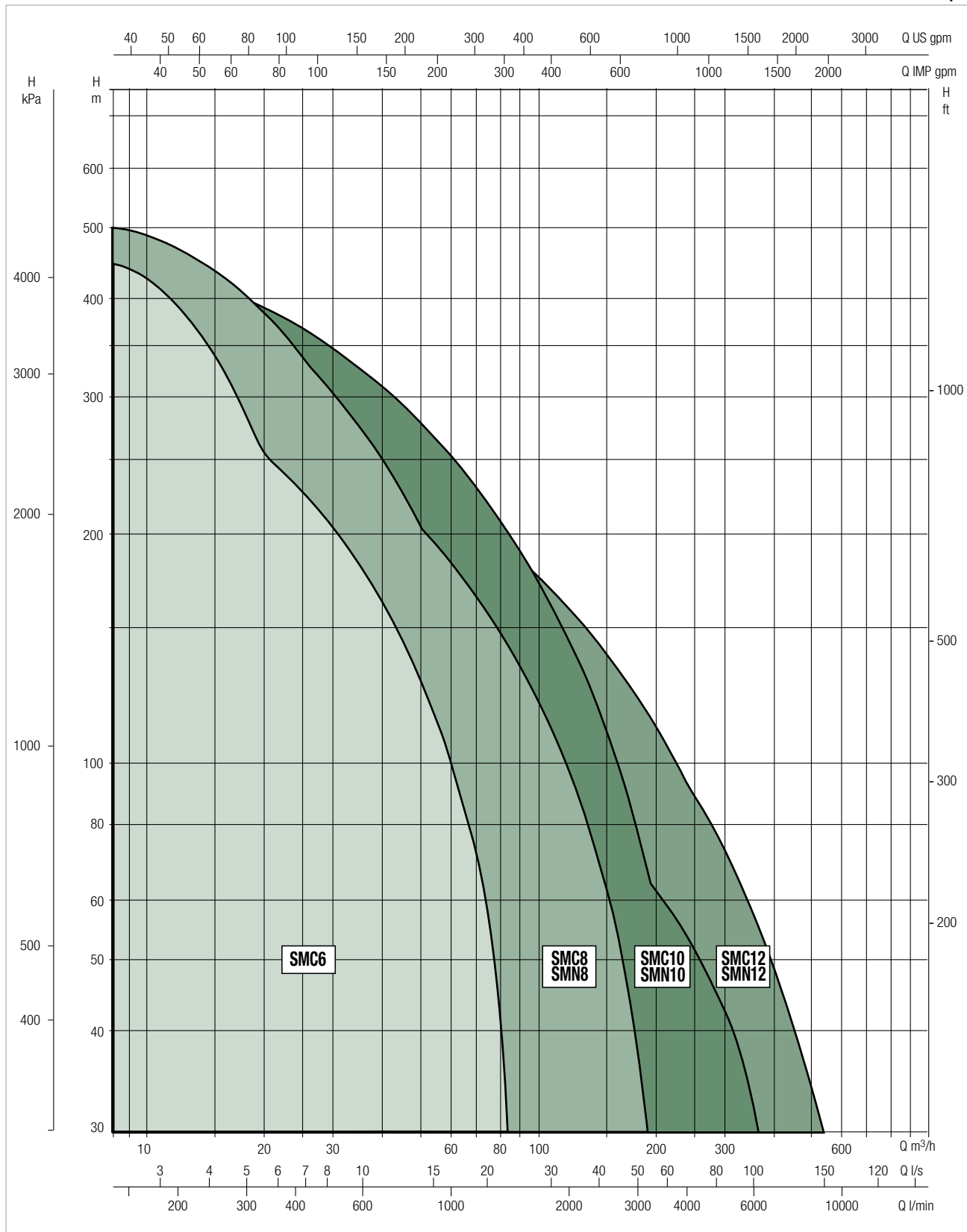

MATERIALS

N.	PARTS	MATERIALS
1	DELIVERY BODY	CAST IRON + CATAPHORESIS
2	NON-RETURN VALVE	CAST IRON + CATAPHORESIS
3	DIFFUSER	CAST IRON + CATAPHORESIS
4	IMPELLER	AISI 316 STAINLESS STEEL
5	SUCTION IMPELLER	AISI 316 STAINLESS STEEL
6	GUIDE BEARING	RUBBER
7	BUSH	BRONZE
8	WEAR RING	BRONZE
9	PUMP SHAFT	STAINLESS STEEL
10	PIPE	STAINLESS STEEL
11	SUCTION BODY	CAST IRON + CATAPHORESIS
12	FILTER GRID	STAINLESS STEEL

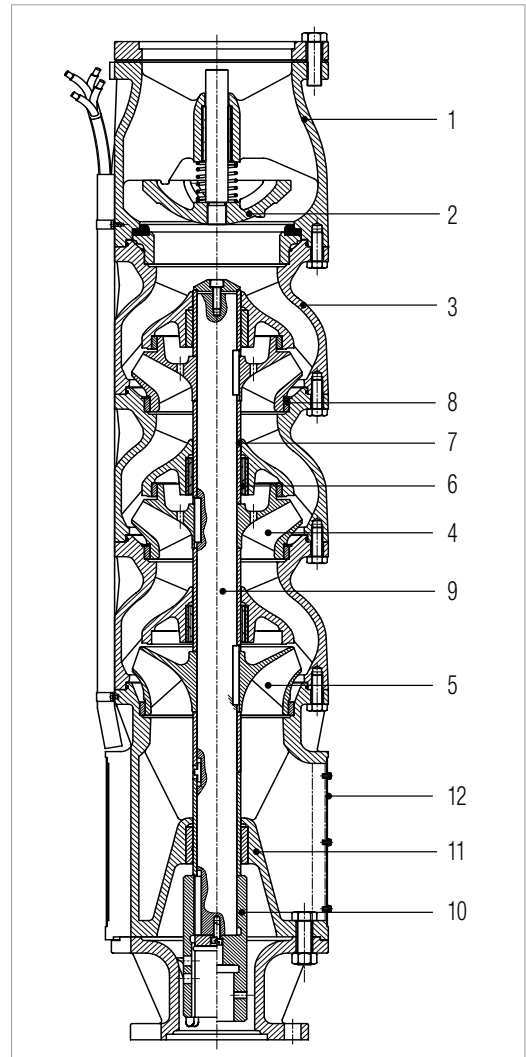

- Denomination index:
(example)

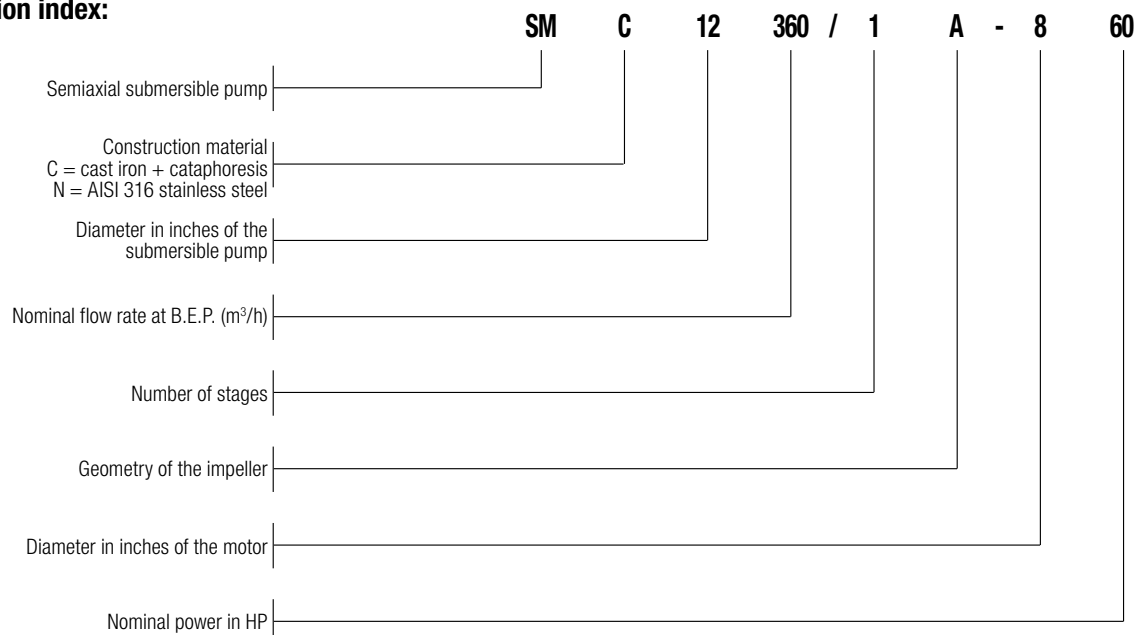

PERFORMANCE 50 HZ - 2 POLES

MODEL	ELECTRICAL DATA		HYDRAULIC DATA													STANDARD MOTOR COUPLING	
	P2 NOMINAL		Q=m ³ h	0	180	210	240	270	285	300	315	330	360	390	420		450
	kW	HP	Q=l/min	0	3000	3500	4000	4500	4750	5000	5250	5500	6000	6500	7000		7500
360/1A	45	60	H (m)	55,5	46	44,5	43	41,5	40,5	39,5	38	36,5	33,5	29,5	25	20	8"
360/1B	55	75		63	51	49,5	48	46,5	46	45	44	42,5	39	35,5	31	26	8"
360/1C	75	100		65,5	54,5	53,5	52	50,5	49,5	49	48	46,5	44	40,5	37	33	8"
360/2A	75	100		100,5	85	82,5	79	75	72,5	69,5	66,5	62,5	53,5	43,5	33	-	8"
360/2B	92	125		117,5	97,5	95	92	88,5	86,5	84	81	77,5	68,5	58,5	47	-	8"
360/2C	110	150		130,5	107,5	106	102,5	99,5	98	96,5	94,5	91,5	85,5	77,5	68,5	57,5	8"
360/3A	132	180		168,5	139	134	129,5	125	122	119,5	116,5	112	101,5	86,5	65	-	10"
360/3B	147	200		185	153,5	149	144	139,5	137	134	131	127	117,5	104,5	87	61,5	10"
360/4A	190	260		224,5	193	188	182,5	176	171,5	167	162	155,5	140	122,5	102	-	10"
360/5A	220	300		295,5	237,5	230	221,5	213,5	207,5	201,5	193	183,5	163,5	138	105	-	12"
360/5B	250	340	319,5	259	252	244,5	236	231	224,5	217,5	208	187,5	166,5	137,5	100	12"	

ELECTRICAL DATA AND DIMENSIONS

MODEL	MOTOR *	ELECTRICAL DATA			OPERATING BY INVERTER	HORIZONTAL INSTALLATION	L2 mm	L mm	L1 mm	D mm	D1 mm	DN	SMC WEIGHT kg	MOTOR WEIGHT kg **
		P2 NOMINAL		In A										
		kW	HP											
360/1A-860	TR8	45	60	92	○	●	2169	1270	899	192	298	7"	136	177
360/1B-875	TR8	55	75	109	○	●	2249	1350	899	192	298	7"	136	192
360/1C-8100	TR8	75	100	145	○	●	2489	1590	899	192	298	7"	136	237
360/2A-8100	TR8	75	100	145	○	●	2689	1590	1099	192	298	7"	174	237
360/2B-8125	TR8	92	125	177	○	●	2929	1830	1099	192	298	7"	174	283
360/2C-8150	TR8	110	150	213	○	●	3184	2060	1124	192	298	7"	178	333
360/3A-10180	TR10	132	180	257	○	●	3194	1870	1324	237	298	7"	217	435
360/3B-10200	TR10	147	200	300	○	●	3394	2070	1324	237	298	7"	217	500
360/4A-10260	TR10	190	260	405	○	●	3924	2400	1524	237	298	7"	255	580
360/5A-12300	TR12	220	300	425	○	△	3834	2110	1724	286	298	7"	294	700
360/5B-12340	TR12	250	340	481	○	△	4004	2280	1724	286	298	7"	294	775

* **6GF motor:** 6" encapsulated water-glycol-filled motor with stator immersed in thermosetting insulating resin
TR motor: 6" - 12" water-filled rewindable motor

** For the weight of the AISI 316 version, please check the reference motor page or contact our sales network.

●	Permitted
○	Only version PE2 + PA
△	Contact our sales network

SMC12 360

SUBMERSIBLE PUMPS

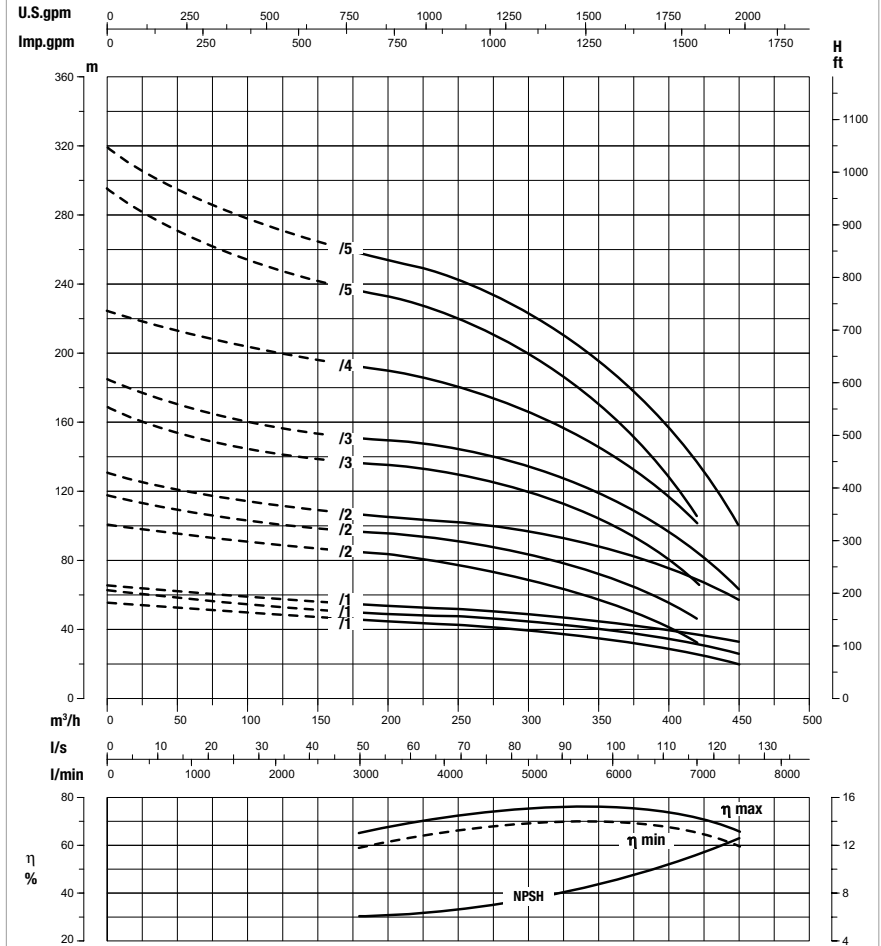
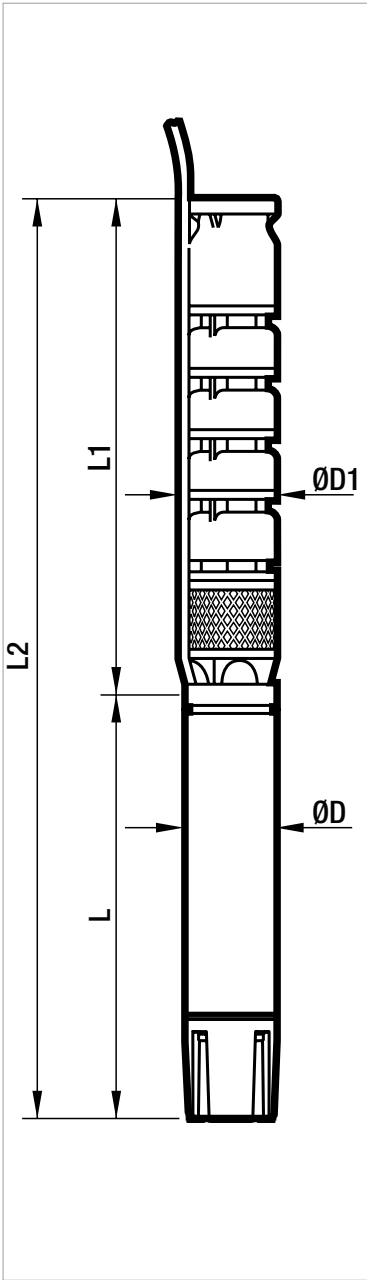

Performance at 50 Hz 2 poles. The performance curves are based on kinematic viscosity values = 1 mm²/s and density equal to 1000 kg/m³. Curve tolerance according to ISO 9906.

SMC12 420

SUBMERSIBLE PUMPS

PERFORMANCE 50 HZ - 2 POLES

MODEL	ELECTRICAL DATA		HYDRAULIC DATA														STANDARD MOTOR COUPLING
	P2 NOMINAL		Q=m ³ h	0	210	240	270	300	330	360	390	420	450	480	510	540	
	kW	HP	Q=l/min	0	3500	4000	4500	5000	5500	6000	6500	7000	7500	8000	8500	9000	
420/1A	45	60	H (m)	52	39,5	38	36,5	35	34	32,5	30,5	28,5	26	22,5	19	14	8"
420/1B	55	75		58,5	44,5	43	41,5	40	39	38	36,5	35	32,5	30	26,5	22	8"
420/2A	92	125		101,5	80,5	78	75,5	73	70,5	67,5	64,5	60,5	56	51,5	46	40,5	8"
420/2B	110	150		114,5	90,5	88	85,5	83	80,5	77,5	74,5	71	66	61	54	46	8"
420/3A	132	180		134	111	107,5	104	100,5	96,5	92,5	88	82	75,5	68	59,5	50,5	10"
420/3B	147	200		156,5	124	120,5	117	114	110	106,5	102,5	97	90,5	83,5	75,5	66,5	10"
420/4A	190	260		196	154	149,5	145	140,5	135,5	130	124	116,5	107,5	97	85,5	72	10"
420/4B	220	300		221	173,5	169	165	161	156,5	152	147	139,5	131	121,5	110,5	96	12"
420/5A	250	340		260,5	204	198	192,5	187	182	176,5	170,5	162	152	139	121,5	100	12"

ELECTRICAL DATA AND DIMENSIONS

MODEL	MOTOR *	ELECTRICAL DATA			OPERATING BY INVERTER	HORIZONTAL INSTALLATION	L2 mm	L mm	L1 mm	D mm	D1 mm	DN	SMC WEIGHT kg	SMN WEIGHT kg	MOTOR WEIGHT kg **
		P2 NOMINAL		In A											
		kW	HP												
420/1A-860	TR8	45	60	92	○	●	2169	1270	899	192	298	7"	134	96	177
420/1B-875	TR8	55	75	109	○	●	2249	1350	899	192	298	7"	134	96	192
420/2A-8125	TR8	92	125	177	○	●	2929	1830	1099	192	298	7"	170	123	283
420/2B-8150	TR8	110	150	213	○	●	3184	2060	1124	192	298	7"	174	123	333
420/3A-10180	TR10	132	180	257	○	●	3194	1870	1324	237	298	7"	211	149	435
420/3B-10200	TR10	147	200	300	○	●	3394	2070	1324	237	298	7"	211	149	500
420/4A-10260	TR10	190	260	405	○	●	3924	2400	1524	237	298	7"	247	176	580
420/4B-12300	TR12	220	300	425	○	△	3634	2110	1524	286	298	7"	247	176	700
420/5A-12340	TR12	250	340	481	○	△	4004	2280	1724	286	298	7"	284	203	775

* **6GF motor:** 6" encapsulated water-glycol-filled motor with stator immersed in thermosetting insulating resin
TR motor: 6" - 12" water-filled rewindable motor

** For the weight of the AISI 316 version, please check the reference motor page or contact our sales network.

●	Permitted
○	Only version PE2 + PA
△	Contact our sales network

SMC12 420

SUBMERSIBLE PUMPS

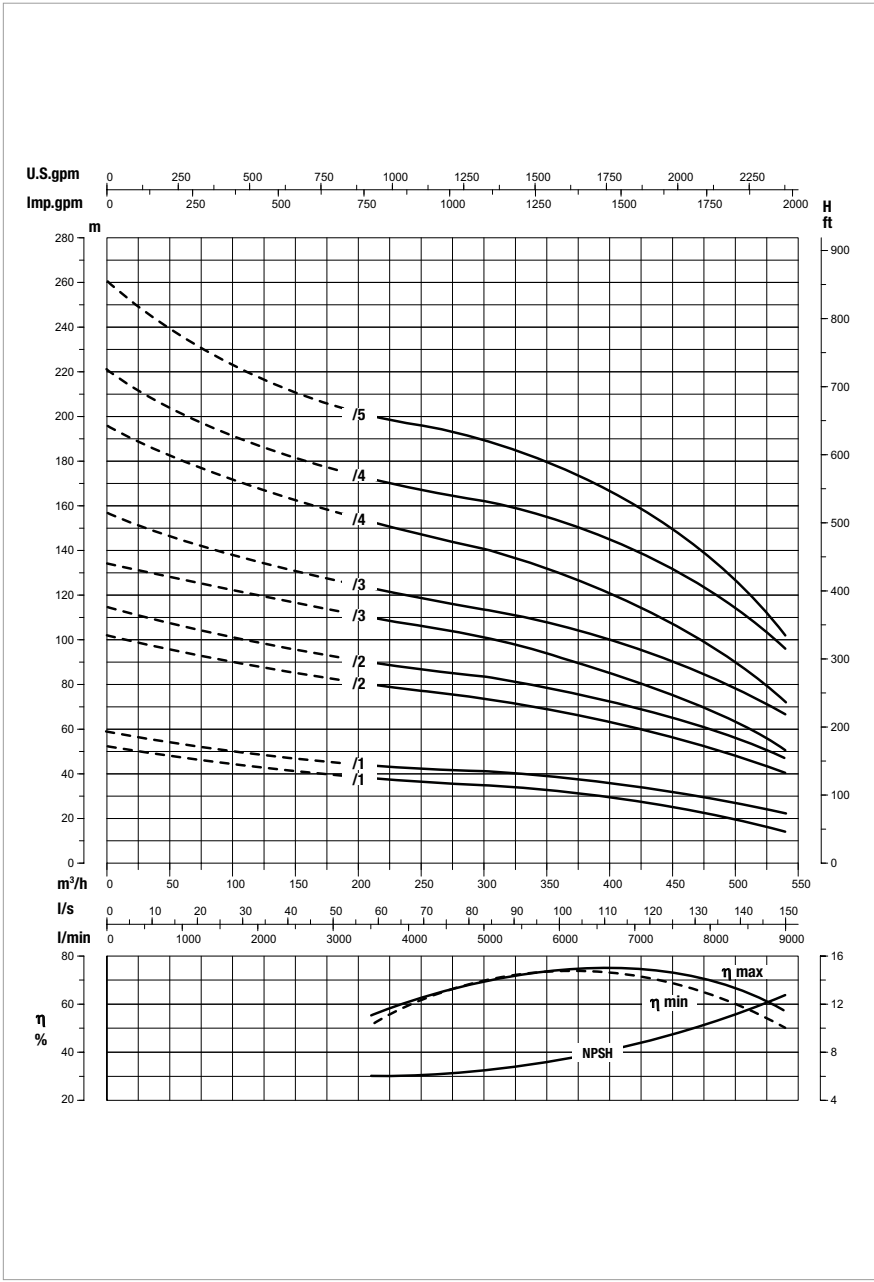
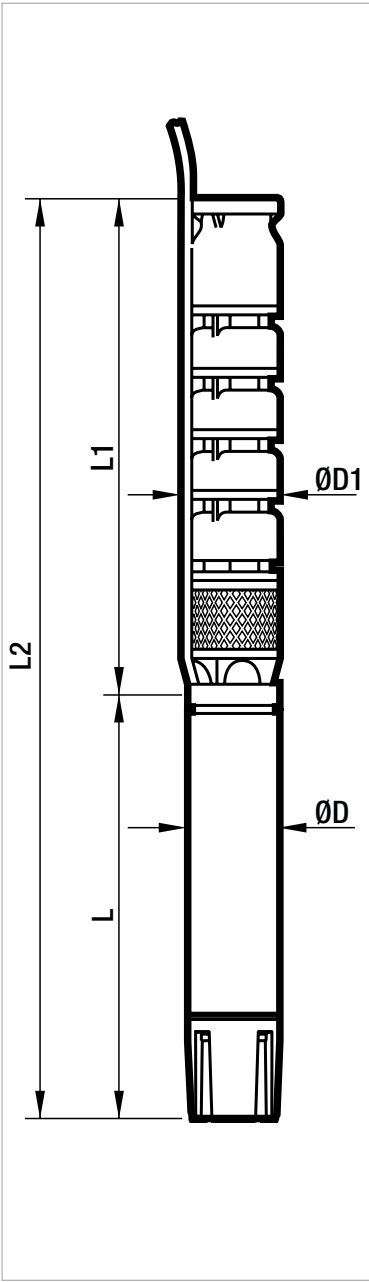

Performance at 50 Hz 2 poles. The performance curves are based on kinematic viscosity values = 1 mm²/s and density equal to 1000 kg/m³. Curve tolerance according to ISO 9906.