



SMC8

TECHNICAL DATA

Flow rate maximum: up to 192 m³/h

Head up to: 500 m

Maximum immersion depth: depending on the motor

Type of pumped liquid: clean, free from solid or abrasive substances, non-viscous, non-aggressive, non-crystallized and chemically neutral

Maximum sand quantity: 80 g/m³

Liquid temperature range: from 0°C to + 30°C

Maximum operating pressure: depending on the motor

Flanges, thread: 5" GAS

Pump maximum diameter: 203 mm

Impeller/s material: pressed AISI 304 stainless steel

Protection class: IP 68

Single phase power input: not available

Three phase power input: 3x230 V 50 Hz / 3x400 V 50 Hz

Power cable (m) and plug: depending on the motor (all the motor are without the power plug)

Possible type of installation: fixed in vertical position. Horizontal installation permitted by removing the non-return valve and installing a cooling jacket (check the applicability of the motor for horizontal use in the dedicated section)

8" multi-impeller semi-axial submersible pump with cast iron stage bodies treated with anti-corrosion cataphoresis paint coating and microcast impellers. Pump designed for pressurization, drawing water from the subsoil, gardening and irrigation in civil and commercial applications and for use in irrigation systems, also in the agricultural sector. The pump is ideal for installation in wells (of at least 8"). The pump is compliant with DM174 for use with water for human consumption.

CONSTRUCTION FEATURES OF THE PUMP

Cast iron pump body treated with cataphoresis paint coating and impellers in microcast AISI 304 stainless steel. The impellers are dynamically balanced and coupled on the shaft with pull tab. Shaft guided with coaxial bush bearings and fully protected with bushes. Integrated non-return valve to reduce localized pressure drops. Stainless steel filter applied to the suction outlet to prevent the entry of dissolved solid bodies. Different types of impeller are available to guarantee the best efficiency at different flow rates and models up to 18 impellers to cover a wide range of heads.

CONSTRUCTION FEATURES OF THE MOTOR

Coupling with 6" or 8" motors depending on the power required by the hydraulic system:

- 6GF: 6" submersible encapsulated motor
- TR6: 6" submersible rewindable motor
- TR8: 8" submersible rewindable motor

For operation with the variable frequency drive, refer to the specifications of the coupled motor.

PERFORMANCE RANGE

The performance curves are based on the kinematic viscosity values = 1 mm²/s and density equal to 1000 kg/m³. Curve tolerance according to ISO 9906.

GRAPHIC SELECTION TABLE

50 Hz - 2900 r.p.m.

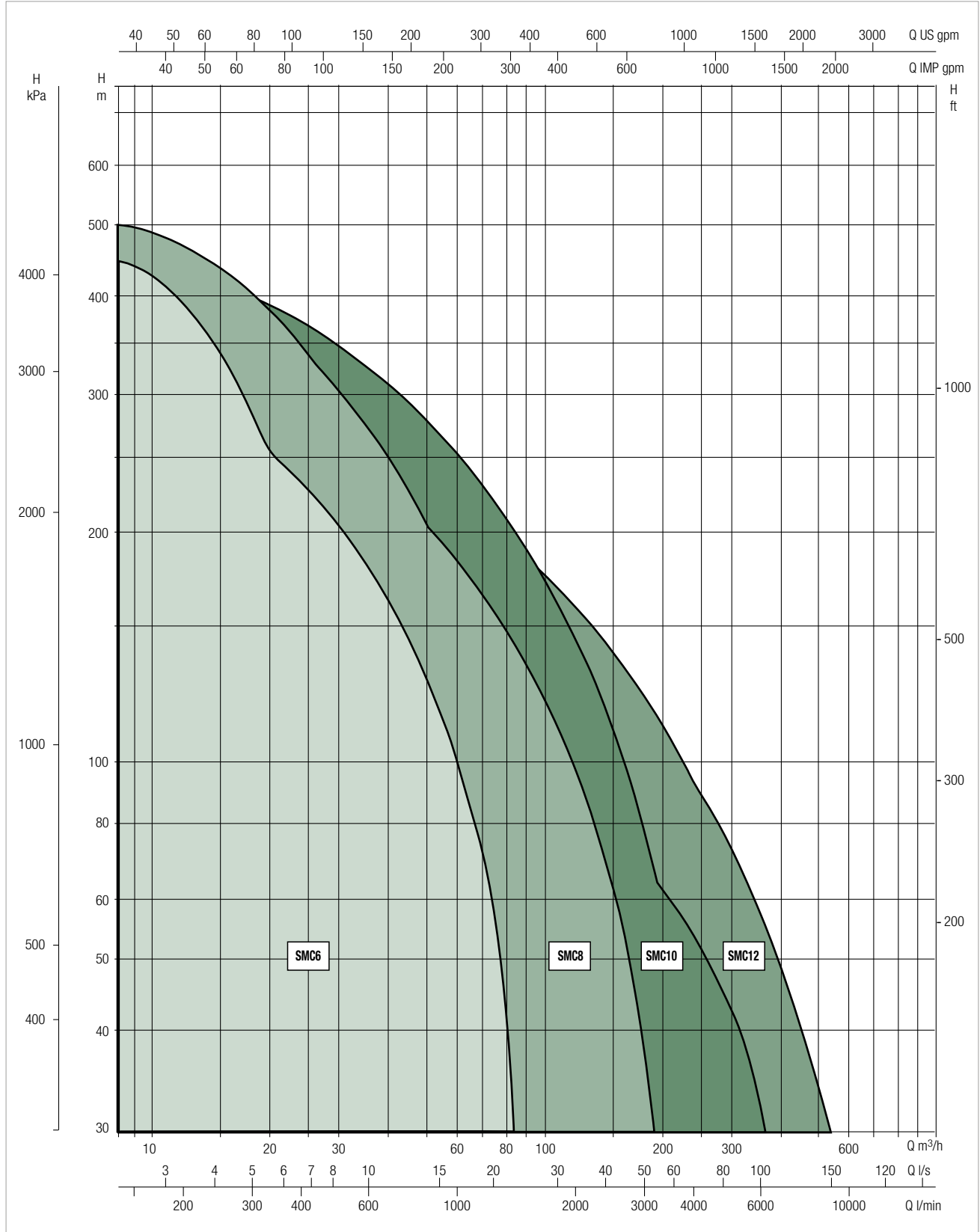

MATERIALS

N.	PARTS	MATERIALS
1	DELIVERY BODY	CAST IRON + CATAPHORESIS
2	NON-RETURN VALVE	STAINLESS STEEL
3	DIFFUSER	CAST IRON + CATAPHORESIS
4	IMPELLER	AISI 304 STAINLESS STEEL
5	GUIDE BEARING	RUBBER
6	BUSH	CHROME-PLATED BRASS
7	WEAR RING	RUBBER
8	PUMP SHAFT	STAINLESS STEEL
9	PIPE	STAINLESS STEEL
10	SUCTION BODY	CAST IRON + CATAPHORESIS
11	FILTER GRID	STAINLESS STEEL

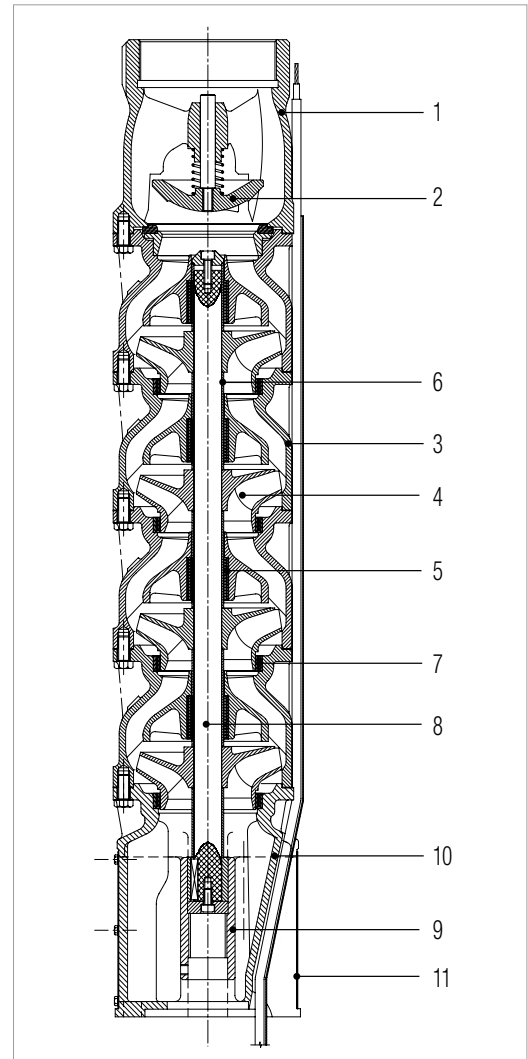

- Denomination index:
(example)

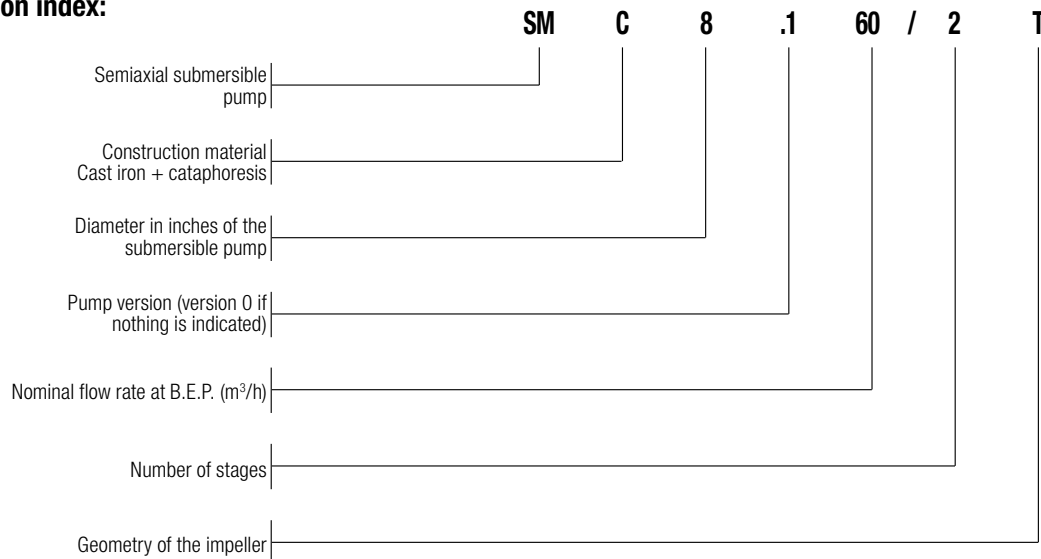

PERFORMANCE 50 HZ - 2 POLES

MODEL	ELECTRICAL DATA		HYDRAULIC DATA													STANDARD MOTOR COUPLING
	P2 NOMINAL		Q=m3h	0	24	36	42	48	54	60	66	72	78	84	90	
	kW	HP	Q=l/min	0	400	600	700	800	900	1000	1100	1200	1300	1400	1500	
60/2T	7,5	10	H (m)	48,5	46	43	41,5	39	37	34	30,5	26,5	22,5	18	13	6"
60/2M	9,3	12,5		55	52	49,5	47,5	46	44	41,5	38	34,5	30,5	26	21	6"
60/2D	11	15		63,5	58	55	53,5	52	50	47,5	44,5	41	36,5	32	27	6"
60/3G	15	20		87	82,5	79	76,5	74	71	67	62	56,5	50,5	43,5	36	6"
60/4I	18,5	25		112	106	101	98	94	89,5	84,5	78	70,5	62,5	53,5	44	6"
60/4D	22	30		125	116,5	111,5	108,5	105,5	101	96,5	90	82,5	74	64,5	54	6"
60/5G	26	35		149	140	134	130,5	126	121	115	107	98	87,5	76,5	64	6"
60/6G	30	40		170,5	163,5	156,5	152	146,5	140,5	133	123	112	99,5	86	71	6"
60/7E	37	50		208	200	193	188	183	176	168	156	144	130	114	97	6"
60/8E	45	60		248	235	226	221	215	208	199	186	172	156	138	118	8"
60/10E	55	75		308	294	283	277	269	259	248	232	214	194	171	146	8"
60/10D	63	85		317	302	292	287	280	271	260	245	228	209	187	162	8"
60/12C	75	100		382	364	352	346	337	327	314	296	275	251	224	194	8"
60/13D	75	100		406	387	375	367	358	346	332	312	289	263	233	201	8"
60/14D	92	125		438	419	406	398	389	377	362	340	316	288	257	222	8"
60/15D	92	125		468	450	436	427	416	403	387	364	337	307	274	236	8"
60/16D	92	125		498	479	464	455	443	429	411	386	358	326	289	249	8"

ELECTRICAL DATA AND DIMENSIONS

MODEL	MOTOR *	ELECTRICAL DATA			OPERATING BY INVERTER	HORIZONTAL INSTALLATION	L2 mm	L mm	L1 mm	D mm	D1 mm	DNM GAS	HYDRAULIC WEIGHT kg	MOTOR WEIGHT kg
		P2 NOMINAL		In A										
		kW	HP											
60/2T	6GF	7,5	10	18	●	●	1296	661	635	141	203	5"	43	47
	TR6	7,5	10	18	○	●	1452	817	635	144	203	5"	43	50
60/2M	6GF	9,3	12,5	22	●	●	1321	686	635	141	203	5"	43	50,1
	TR6	9,3	12,5	21	○	●	1482	847	635	144	203	5"	43	52
60/2D	6GF	11	15	25,5	●	●	1366	731	635	141	203	5"	43	54,5
	TR6	11	15	25	○	●	1512	877	635	144	203	5"	43	57
60/3G	6GF	15	20	33,4	●	●	1531	786	745	141	203	5"	53	61
	TR6	15	20	32	○	●	1722	977	745	144	203	5"	53	74
60/4I	6GF	18,5	25	41	●	●	1716	861	855	141	203	5"	63	68,5
	TR6	18,5	25	39	○	●	1892	1037	855	144	203	5"	63	80
60/4D	6GF	22	30	47	●	●	1776	921	855	141	203	5"	63	74,3
	TR6	22	30	49	○	●	1922	1067	855	144	203	5"	63	92
60/5G	6GF	26	35	57	●	●	1945	980	965	141	203	5"	73	78
	TR6	26	35	58	○	●	2102	1137	965	144	203	5"	73	103
60/6G	6GF	30	40	61,5	●	●	2126	1051	1075	141	203	5"	83	88,5
	TR6	30	40	65	○	●	2267	1192	1075	144	203	5"	83	107
60/7E	6GF	37	50	79,3	●	●	2366	1181	1185	141	203	5"	93	101,6
	TR6	37	50	80	○	●	2477	1292	1185	144	203	5"	93	113
60/8E	TR8	45	60	92	○	●	2565	1270	1295	192	203	5"	103	177
60/10E	TR8	55	75	109	○	●	2865	1350	1515	192	203	5"	123	192
60/10D	TR8	63	85	126	○	●	3005	1490	1515	192	203	5"	123	218
60/12C	TR8	75	100	145	○	●	3325	1590	1735	192	203	5"	143	237
60/13D	TR8	75	100	145	○	●	3435	1590	1845	192	203	5"	153	237
60/14D	TR8	92	125	177	○	●	3785	1830	1955	192	203	5"	163	283
60/15D	TR8	92	125	177	○	●	3895	1830	2065	192	203	5"	173	283
60/16D	TR8	92	125	177	○	●	4005	1830	2175	192	203	5"	183	283

* **6GF motor:** 6" encapsulated water-glycol-filled motor with stator immersed in thermosetting insulating resin
TR motor: 6" - 12" water-filled rewindable motor

●	Permitted
○	Only version PE2 + PA
△	Contact our sales network

SMC8.1 60

SUBMERSIBLE PUMPS

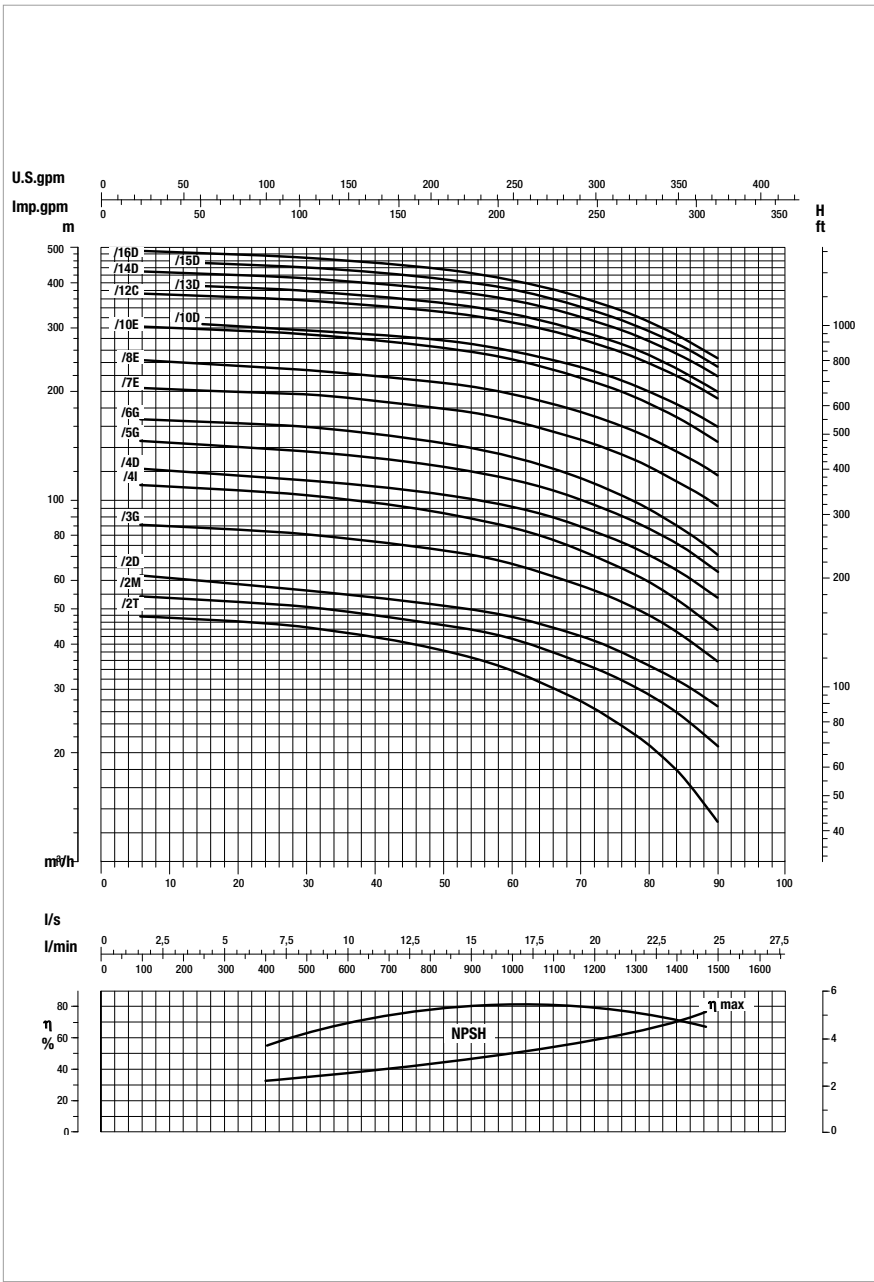
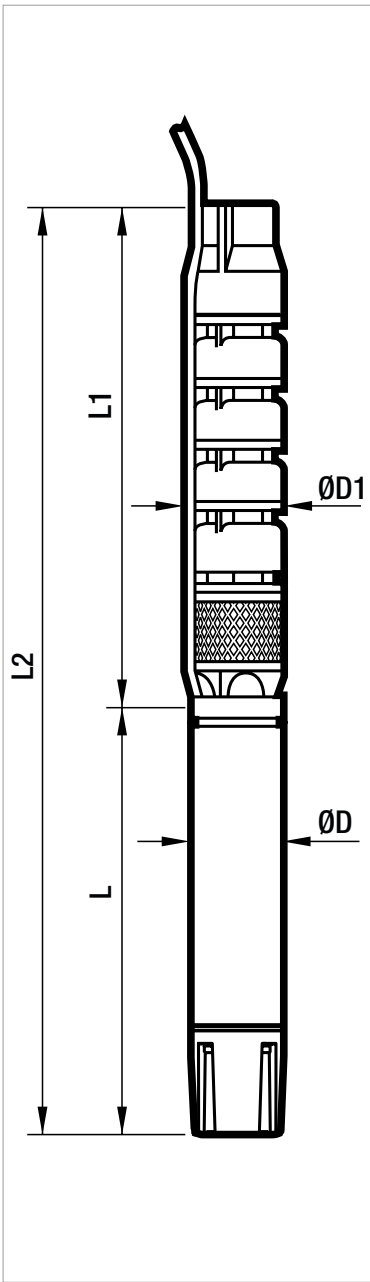

Performance at 50 Hz 2 poles. The performance curves are based on kinematic viscosity values = 1 mm²/s and density equal to 1000 kg/m³. Curve tolerance according to ISO 9906.

PERFORMANCE 50 HZ - 2 POLES

MODEL	ELECTRICAL DATA		HYDRAULIC DATA													STANDARD MOTOR COUPLING
	P2 NOMINAL		Q=m3h	0	24	36	54	72	78	84	90	96	102	108	120	
	kW	HP	Q=l/min	0	400	600	900	1200	1300	1400	1500	1600	1700	1800	2000	
85/2H	7,5	10	H (m)	47,5	37,5	33,5	31,5	29	27,5	25,5	23,5	21	18,5	16	9,5	6"
85/2C	9,3	12,5		54,5	43	39	36,5	34,5	33,5	31,5	29,5	27,5	25	22,5	16,5	6"
85/3H	11	15		71,5	56,5	50,5	47,5	44	41,5	38,5	35,5	32	28	24	14,5	6"
85/4H	15	20		95	75,5	67,5	63,5	58,5	55,5	52	47,5	42,5	37,5	32	20	6"
85/5I	18,5	25		117	93	82,5	77	71	67	62,5	56,5	50,5	44,5	37,5	22	6"
85/5D	22	30		128,5	103,5	93,5	88,5	83	79	74,5	68,5	62,5	55,5	48	33,5	6"
85/6D	26	35		154,5	124,5	112,5	106	99	94,5	89	82	75	67	59	40,5	6"
85/7D	30	40		177,5	143	128	120,5	113	107	101	93	84,5	75,5	66	45	6"
85/8B	37	50		214	173,5	155,5	147	138	131,5	124,5	115,5	106	95,5	84,5	60,5	6"
85/9A	45	60		250	205	185	175	165	158,5	150,5	140,5	130	118,5	106	79,5	8"
85/11A	55	75		304,5	249,5	225,5	214	202,5	194	184	171,5	158,5	144	129	95	8"
85/12A	63	85		330,5	270,5	245	232,5	220,5	211	200,5	187	172,5	157	140	102	8"
85/14A	75	100		389	316,5	286	271,5	257	246	233,5	218	201	183	163,5	120	8"
85/15A	75	100		416,5	339	306,5	291	275,5	263,5	250,5	233,5	215,5	196	175	128,5	8"
85/16A	92	125		444,5	361,5	327	310,5	294	281	267	249	230	209,5	187	137	8"
85/17A	92	125		472,5	384	347,5	330	312	298,5	284	265	244,5	222,5	198,5	146	8"
85/18A	92	125		500	407	367,5	349	330,5	316	300,5	280,5	258,5	235,5	210,5	154,5	8"

ELECTRICAL DATA AND DIMENSIONS

MODEL	MOTOR *	ELECTRICAL DATA			OPERATING BY INVERTER	HORIZONTAL INSTALLATION	L2 mm	L mm	L1 mm	D mm	D1 mm	DN GAS	HYDRAULIC WEIGHT kg	MOTOR WEIGHT kg
		P2 NOMINAL		In A										
		kW	HP											
85/2H	6GF	7,5	10	18	●	●	1348	661	687	141	196	5"	42	47
	TR6	7,5	10	18	○	●	1504	817	687	144	196	5"	42	50
85/2C	6GF	9,3	12,5	22	●	●	1373	686	687	141	196	5"	42	50,1
	TR6	9,3	12,5	21	○	●	1534	847	687	144	196	5"	42	52
85/3H	6GF	11	15	25,5	●	●	1554	731	823	141	196	5"	52	54,5
	TR6	11	15	25	○	●	1700	877	823	144	196	5"	52	57
85/4H	6GF	15	20	33,4	●	●	1745	786	959	141	196	5"	63	61
	TR6	15	20	32	○	●	1936	977	959	144	196	5"	63	74
85/5I	6GF	18,5	25	41	●	●	1956	861	1095	141	196	5"	73	68,5
	TR6	18,5	25	39	○	●	2132	1037	1095	144	196	5"	73	80
85/5D	6GF	22	30	47	●	●	2016	921	1095	141	196	5"	73	74,3
	TR6	22	30	49	○	●	2162	1067	1095	144	196	5"	73	92
85/6D	6GF	26	35	57	●	●	2211	980	1231	141	196	5"	84	78
	TR6	26	35	58	○	●	2368	1137	1231	144	196	5"	84	103
85/7D	6GF	30	40	61,5	●	●	2418	1051	1367	141	196	5"	96	88,5
	TR6	30	40	65	○	●	2559	1192	1367	144	196	5"	96	107
85/8B	6GF	37	50	79,3	●	●	2684	1181	1503	141	198	5"	106	101,6
	TR6	37	50	80	○	●	2795	1292	1503	144	198	5"	106	113
85/9A	TR8	45	60	92	○	●	2909	1270	1639	192	198	5"	117	177
85/11A	TR8	55	75	109	○	●	3261	1350	1911	192	198	5"	138	192
85/12A	TR8	63	85	126	○	●	3537	1490	2047	192	200	5"	149	218
85/14A	TR8	75	100	145	○	●	3909	1590	2319	192	200	5"	170	237
85/15A	TR8	75	100	145	○	●	4045	1590	2455	192	200	5"	181	237
85/16A	TR8	92	125	177	○	●	4421	1830	2591	192	202	5"	192	283
85/17A	TR8	92	125	177	○	●	4557	1830	2727	192	202	5"	202	283
85/18A	TR8	92	125	177	○	●	4693	1830	2863	192	202	5"	213	283

* **6GF motor:** 6" encapsulated water-glycol-filled motor with stator immersed in thermosetting insulating resin
TR motor: 6" - 12" water-filled rewindable motor

●	Permitted
○	Only version PE2 + PA
△	Contact our sales network

SMC8.1 85

SUBMERSIBLE PUMPS

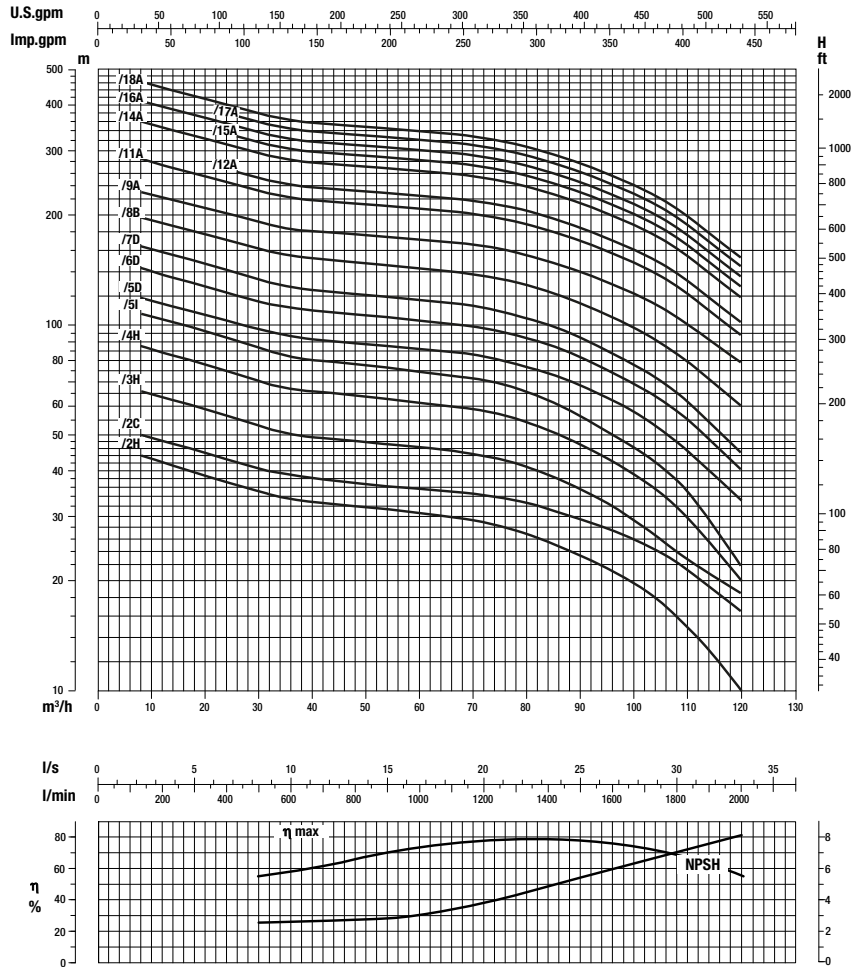
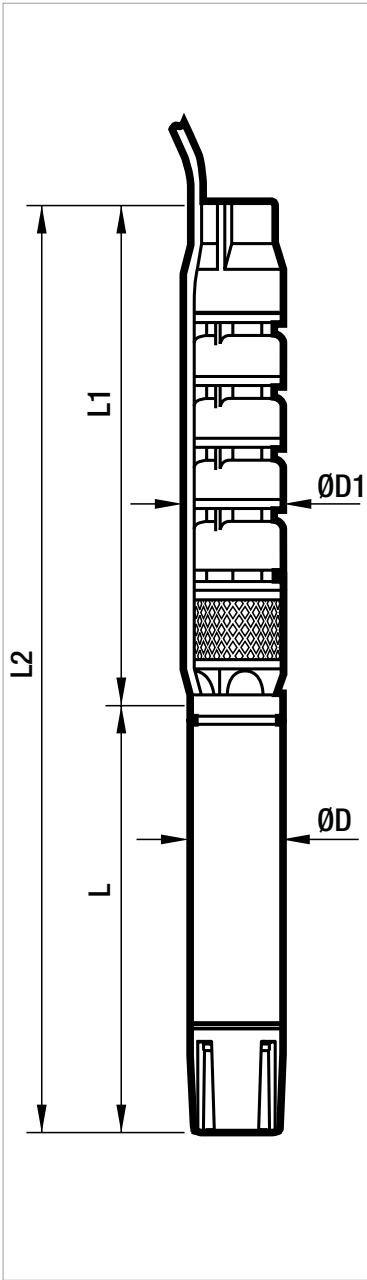

Performance at 50 Hz 2 poles. The performance curves are based on kinematic viscosity values = 1 mm²/s and density equal to 1000 kg/m³. Curve tolerance according to ISO 9906.

SMC8 110

SUBMERSIBLE PUMPS

PERFORMANCE 50 HZ - 2 POLES

MODEL	ELECTRICAL DATA		HYDRAULIC DATA													STANDARD MOTOR COUPLING
	P2 NOMINAL		Q=m3h	0	36	66	84	96	102	108	114	120	126	138	156	
	kW	HP	Q=l/min	0	600	1100	1400	1600	1700	1800	1900	2000	2100	2300	2600	
110/2H	13	17,5	H (m)	47,5	42,5	39,5	37	35,5	34,5	33,5	32	30,5	28,5	24,5	17	6"
110/3G	18,5	25		69,5	63	57,5	53	50,5	49	47	45	42	39,5	33	22	6"
110/3B	22	30		76	69	64	60,5	57,5	56	54	51,5	49	46	39	27,5	6"
110/4F	26	35		95	87,5	80,5	75,5	72	69,5	67	63,5	60	56	47,5	32,5	6"
110/5I	30	40		112,5	103,5	95	89	84	81,5	78	74	69,5	64,5	53,5	35,5	6"
110/5F	37	50		118	109,5	101,5	95,5	91	88	85	80,5	76	71	60,5	41,5	6"
110/6H	37	50		137,5	126	117	109,5	103,5	100	96	90,5	85	79	66	45	6"
110/6F	45	60		144,5	134	124,5	117,5	112	109	105,5	100,5	95	89	76	53,5	8"
110/6B	45	60		155,5	144	134,5	127	121	117,5	113,5	108,5	102,5	96,5	83	59,5	8"
110/7C	55	75		178,5	165,5	154	146	139	135	130,5	124,5	117,5	110	92,5	63,5	8"
110/9L	55	75		200,5	186	171,5	161,5	154	149	143	136	127,5	118,5	98,5	66	8"
110/9G	63	85		209	194,5	180	170	162	157	152	146	137,5	128,5	108,5	74,5	8"
110/9B	75	100		225,5	212	196,5	185,5	176,5	171,5	165,5	159	150,5	141	121	88	8"
110/10B	75	100		251	235,5	218	206	196	190,5	184	177	167,5	157	134,5	97,5	8"
110/11B	92	125		276	259	240	226,5	215,5	209,5	202,5	194,5	184	172,5	147,5	107,5	8"
110/13E	92	125		313	294	272	257	244,5	238	230	221	209	196,5	167,5	117,5	8"
110/14C	110	150		351	329,5	305,5	288,5	274,5	266,5	257,5	247,5	234	219,5	188	137	8"
110/15C	110	150		376	353	327,5	309	294	285,5	276	265,5	251	235,5	201,5	146,5	8"

ELECTRICAL DATA AND DIMENSIONS

MODEL	MOTOR *	ELECTRICAL DATA			OPERATING BY INVERTER	HORIZONTAL INSTALLATION	L2 mm	L mm	L1 mm	D mm	D1 mm	DN GAS	WEIGHT kg	MOTOR WEIGHT kg **
		P2 NOMINAL		In A										
		kW	HP											
110/2H-617	6GF	13	17,5	28,7	●	●	1490	761	729	141	196	5"	43	58,4
	TR6	13	17,5	29	○	●	1636	907	729	144	196	5"	43	63
110/3G-625	6GF	18,5	25	41	●	●	1747	861	886	141	196	5"	55	69
	TR6	18,5	25	39	○	●	1923	1037	886	144	196	5"	55	80
110/3B-630	6GF	22	30	47	●	●	1807	921	886	141	196	5"	55	74
	TR6	22	30	49	○	●	1953	1067	886	144	196	5"	55	95
110/4F-635	6GF	26	35	57	●	●	2023	980	1043	141	196	5"	67	78
	TR6	26	35	58	○	●	2180	1137	1043	144	196	5"	67	103
110/5I-640	6GF	30	40	61,5	●	●	2251	1051	1200	141	196	5"	79	89
	TR6	30	40	65	○	●	2392	1192	1200	144	196	5"	79	110
110/5F-650	6GF	37	50	79,3	●	●	2381	1181	1200	141	198	5"	79	102
	TR6	37	50	80	○	●	2492	1292	1200	144	198	5"	79	113
110/6H-650	6GF	37	50	79,3	●	●	2538	1181	1357	141	198	5"	91	102
	TR6	37	50	80	○	●	2649	1292	1357	144	198	5"	91	113
110/6F-860	TR8	45	60	92	○	●	2627	1270	1357	192	198	5"	93	177
110/6B-860	TR8	45	60	92	○	●	2627	1270	1357	192	198	5"	93	177
110/7C-875	TR8	55	75	109	○	●	2864	1350	1514	192	198	5"	105	192
110/9L-875	TR8	55	75	109	○	●	3178	1350	1828	192	198	5"	129	192
110/9G-885	TR8	63	85	126	○	●	3318	1490	1828	192	198	5"	129	218
110/9B-8100	TR8	75	100	145	○	●	3418	1590	1828	192	200	5"	129	237
110/10B-8100	TR8	75	100	145	○	●	3575	1590	1985	192	200	5"	142	237
110/11B-8125	TR8	92	125	177	○	●	3972	1830	2142	192	202	5"	154	283
110/13E-8125	TR8	92	125	177	○	●	4286	1830	2456	192	202	5"	178	283
110/14C-8150	TR8	110	150	213	○	●	4673	2060	2613	192	202	5"	190	333
110/15C-8150	TR8	110	150	213	○	●	4830	2060	2770	192	202	5"	203	333

* **6GF motor:** 6" encapsulated water-glycol-filled motor with stator immersed in thermosetting insulating resin
TR motor: 6" - 12" water-filled rewindable motor

** For the weight of the AISI 316 version, please check the reference motor page or contact our sales network.

●	Permitted
○	Only version PE2 + PA
⚠	Contact our sales network

SMC8 110

SUBMERSIBLE PUMPS

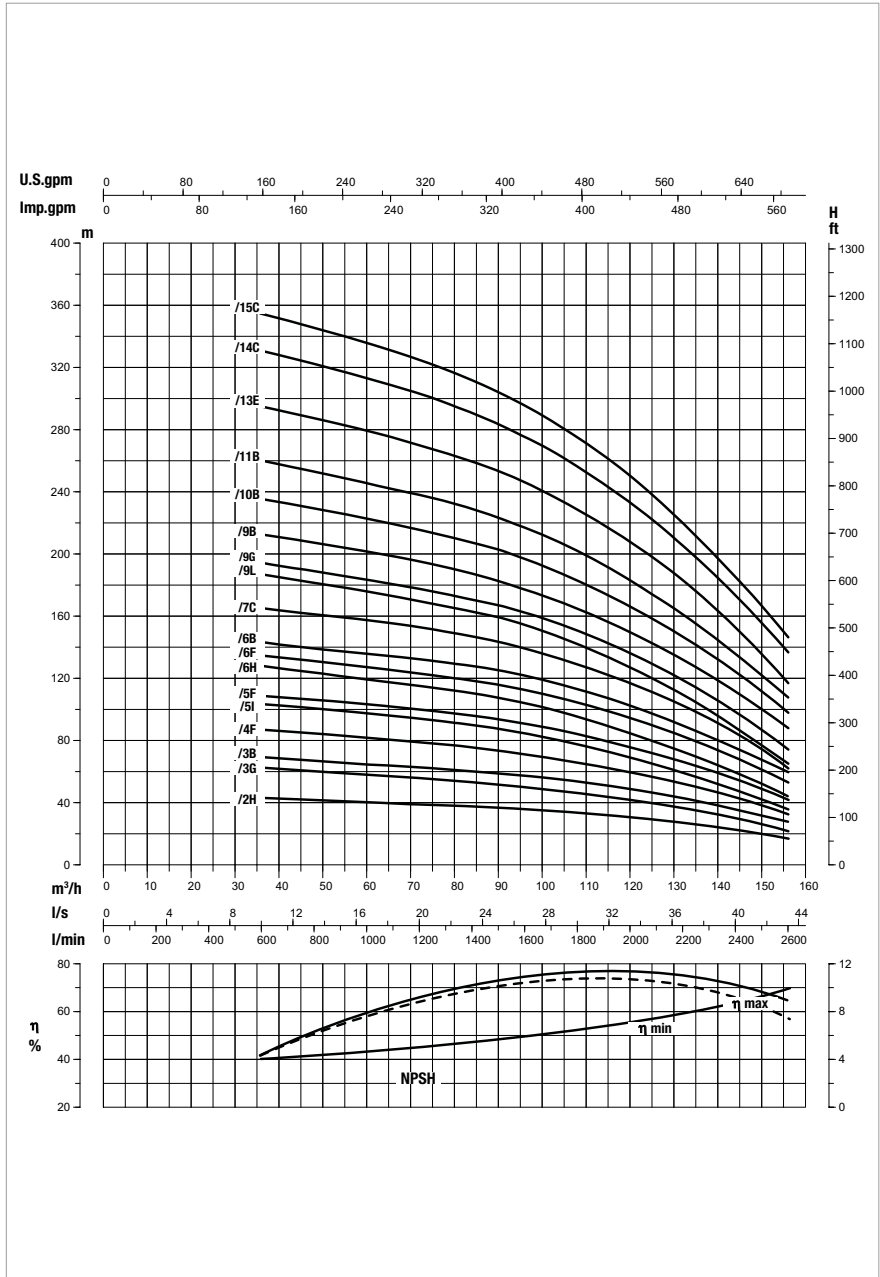
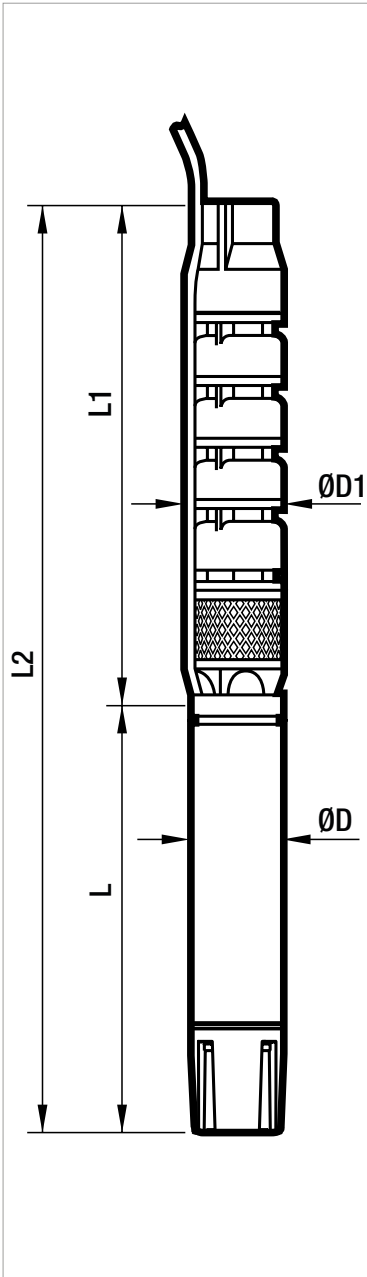

Performance at 50 Hz 2 poles. The performance curves are based on kinematic viscosity values = 1 mm²/s and density equal to 1000 kg/m³. Curve tolerance according to ISO 9906.

PERFORMANCE 50 HZ - 2 POLES

MODEL	ELECTRICAL DATA		Q=m3h Q=l/min	HYDRAULIC DATA												STANDARD MOTOR COUPLING
	P2 NOMINAL			0	36	72	96	108	120	132	144	156	168	180	192	
	kW	HP		0	600	1200	1600	1800	2000	2200	2400	2600	2800	3000	3200	
135/2M	13	17,5	H (m)	47,5	42	37,5	34,5	33	30,5	28	24,5	20,5	16	12	8,5	6"
135/2F	15	20		52	46	41	38,5	36,5	34,5	32	29	25	21	16,5	12	6"
135/2C	18,5	25		55	48,5	43,5	41	39	37	34,5	31	27	23	19	15,5	6"
135/3N	18,5	25		63,5	58,5	53,5	49	45,5	42	37	32	26	20	14		6"
135/3L	22	30		70	64	57,5	53	50,5	47	42,5	37,5	31,5	25	19	13,5	6"
135/3B	26	35		82,5	75	68,5	64	61	58	54,5	49,5	43	36	29,5	22	6"
135/4E	30	40		101	90	82	76,5	72,5	68,5	63	56,5	49,5	41,5	33	24	6"
135/4C	37	50		106	95	88	82	78	73,5	68	61,5	54	45,5	36,5	26,5	6"
135/5F	37	50		121,5	111	101,5	94	89	84	77,5	69	60	50	39,5	28	6"
135/5E	45	60		128,5	118	108	100	95,5	90,5	84,5	77	68	58,5	47,5	35,5	8"
135/6F	45	60		151	135,5	125	116	110,5	104	96,5	86,5	76	64	51,5	38	8"
135/7G	55	75		176	159,5	147	137	130,5	123	114	102	89	75	60	44,5	8"
135/7E	55	75		181	164	151,5	141,5	135,5	128	119	107	94	80	65	49,5	8"
135/8G	63	85		201,5	182	168	156,5	149,5	140,5	130	117	102	85,5	68,5	51	8"
135/9G	75	100		220	200,5	185	171,5	163	153,5	141,5	127	110,5	93	74	54	8"
135/9C	75	100		238	219,5	201,5	187	178,5	169	158	143,5	128	110,5	91	69,5	8"
135/11C	92	125	291	268,5	246,5	228,5	218	206,5	193	175,5	156,5	135	111	85	8"	
135/13C	110	150	343,5	317	291	270	258	244	228	207,5	185	159,5	131,5	100,5	8"	

ELECTRICAL DATA AND DIMENSIONS

MODEL	MOTOR *	ELECTRICAL DATA			OPERATING BY INVERTER	HORIZONTAL INSTALLATION	L2 mm	L mm	L1 mm	D mm	D1 mm	DN GAS	WEIGHT kg	MOTOR WEIGHT kg **
		P2 NOMINAL		In A										
		kW	HP											
135/2M-617	6GF	13	17,5	28,7	●	●	1490	761	729	141	196	5"	43	58,4
	TR6	13	17,5	29	○	●	1636	907	729	144	196	5"	43	63
135/2F-620	6GF	15	20	33,4	●	●	1515	786	729	141	196	5"	43	61
	TR6	15	20	32	○	●	1706	977	729	144	196	5"	43	77
135/2C-625	6GF	18,5	25	41	●	●	1590	861	729	141	196	5"	43	69
	TR6	18,5	25	39	○	●	1766	1037	729	144	196	5"	43	80
135/3N-625	6GF	18,5	25	41	●	●	1747	861	886	141	196	5"	55	69
	TR6	18,5	25	39	○	●	1923	1037	886	144	196	5"	55	80
135/3L-630	6GF	22	30	47	●	●	1807	921	886	141	196	5"	55	74
	TR6	22	30	49	○	●	1953	1067	886	144	196	5"	55	95
135/3B-635	6GF	26	35	57	●	●	1866	980	886	141	196	5"	55	78
	TR6	26	35	58	○	●	2023	1137	886	144	196	5"	55	103
135/4E-640	6GF	30	40	61,5	●	●	2094	1051	1043	141	196	5"	67	89
	TR6	30	40	65	○	●	2235	1192	1043	144	196	5"	67	110
135/4C-650	6GF	37	50	79,3	●	●	2224	1181	1043	141	198	5"	67	102
	TR6	37	50	80	○	●	2335	1292	1043	144	198	5"	67	113
135/5F-650	6GF	37	50	79,3	●	●	2381	1181	1200	141	198	5"	79	102
	TR6	37	50	80	○	●	2492	1292	1200	144	198	5"	79	113
135/5E-860	TR8	45	60	92	○	●	2470	1270	1200	192	198	5"	81	177
135/6F-860	TR8	45	60	92	○	●	2627	1270	1357	192	198	5"	93	177
135/7G-875	TR8	55	75	109	○	●	2864	1350	1514	192	198	5"	105	192
135/7E-875	TR8	55	75	109	○	●	2864	1350	1514	192	198	5"	105	192
135/8G-885	TR8	63	85	126	○	●	3161	1490	1671	192	198	5"	117	218
135/9G-8100	TR8	75	100	145	○	●	3418	1590	1828	192	200	5"	129	237
135/9C-8100	TR8	75	100	145	○	●	3418	1590	1828	192	200	5"	129	237
135/11C-8125	TR8	92	125	177	○	●	3972	1830	2142	192	202	5"	154	283
135/13C-8150	TR8	110	150	213	○	●	4516	2060	2456	192	202	5"	178	333

* 6GF motor: 6" encapsulated water-glycol-filled motor with stator immersed in thermosetting insulating resin
 TR motor: 6" - 12" water-filled rewindable motor

** For the weight of the AISI 316 version, please check the reference motor page or contact our sales network.

●	Permitted
○	Only version PE2 + PA
△	Contact our sales network

SMC8 135

SUBMERSIBLE PUMPS

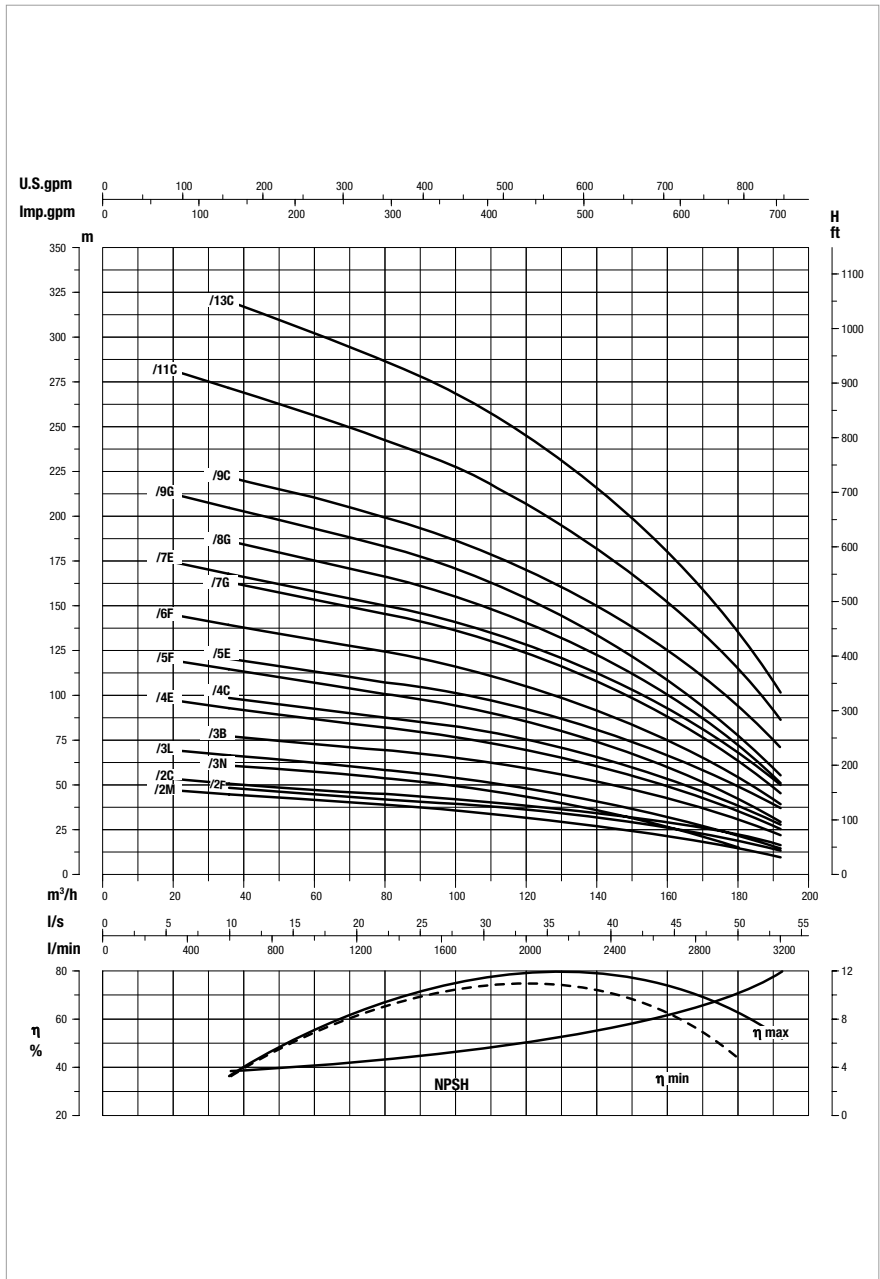
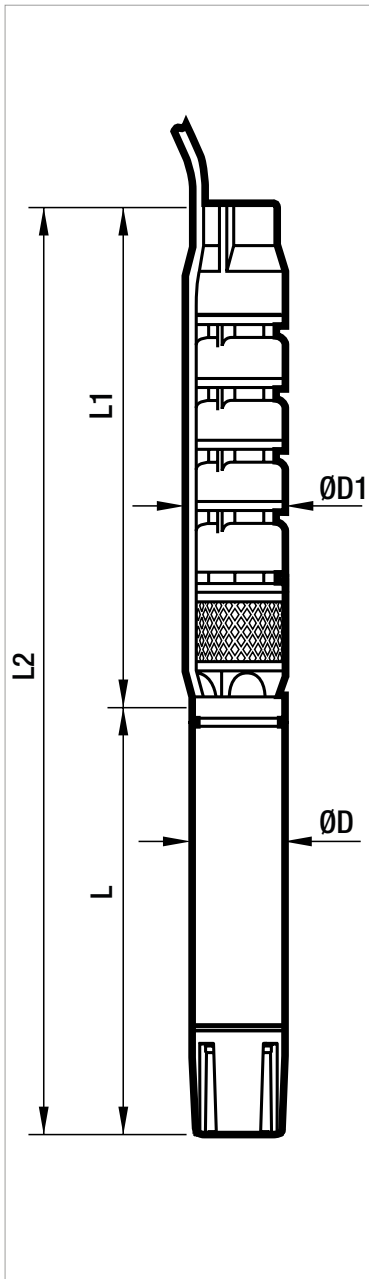

Performance at 50 Hz 2 poles. The performance curves are based on kinematic viscosity values = 1 mm²/s and density equal to 1000 kg/m³. Curve tolerance according to ISO 9906.