



TECHNICAL DATA

Flow rate maximum: up to 210 m³/h

Head up to: 555 m

Maximum immersion depth: depending on the motor

Type of pumped liquid: clean, free from solid or abrasive substances, non-viscous, non-aggressive, non-crystallized and chemically neutral. The version in AISI 316 stainless steel is also suitable for aggressive solutions and/or salt water

Maximum sand quantity: 50 g/m³

Liquid temperature range: from 0°C to +50°C (depending on the motor)

Maximum operating pressure: depending on the motor

Flanges, thread: 6"

Pump maximum diameter: 226 mm

Impeller/s material/i: pressed AISI 304 stainless steel

Protection class: IP 68

Single phase power input: not available

Three phase power input: 3x230 V 50 Hz / 3x400 V 50 Hz

Power cable (m) and plug: depending on the motor (all the motor are without the power plug)

Possible type of installation: fixed in vertical position. Horizontal installation permitted by removing the non-return valve and installing a cooling jacket (check the applicability of the motor for horizontal use in the dedicated section)

Special versions on request: molded AISI 316 stainless steel construction (impellers and pump body) for aggressive water applications, delivery ports with NPT standard

8" semi axial multi-impeller submersible pump in molded AISI 304 or AISI 316 stainless steel, designed for pressurization, lifting water from wells, gardening and irrigation in commercial building service and irrigation also in agriculture. Ideal for installation in wells.

CONSTRUCTION FEATURES OF THE PUMP

Diffusers, impellers, supports, delivery and suction made entirely of pressed AISI 304 steel or AISI 316. Impellers balanced and keyed to the shaft with a conical coupling, specially developed to guarantee: easy assembly, avoid malfunctions due to vibrations during rotation and reduce operating noise. Shaft driven by water lubricated bearings. The diffuser geometry facilitates the expulsion of sand particles with the pumped liquid and limits the infiltration of water between the stage. Integrated non-return valve to reduce localized pressure drops. Stainless steel filter applied to the suction mouth to prevent the entry of dissolved solid bodies. Delivery port threaded according to the GAS standard. Different types of impeller are available to guarantee the best efficiency at different flow rates and models up to 20 impellers to cover a wide range of heads.

CONSTRUCTION FEATURES OF THE MOTOR

Coupling with 6" or 10" motors depending on the power required by the hydraulic system:

- 6GF: 6" submersible encapsulated motor
- TR6: 6" submersible rewindable motor
- TR8: 8" submersible rewindable motor
- TR10: 10" submersible rewindable motor

For operation with the variable frequency drive, refer to the specifications of the coupled motor.

For hydraulic systems in AISI 316 stainless steel, we recommend coupling with motors made of AISI 316 or DUPLEX stainless steel (check availability of the selected model).

PERFORMANCE RANGE

The performance curves are based on the kinematic viscosity values = 1 mm²/s and density equal to 1000 kg/m³. Curve tolerance according to ISO 9906.

GRAPHIC SELECTION TABLE

50 Hz - 2900 r.p.m.

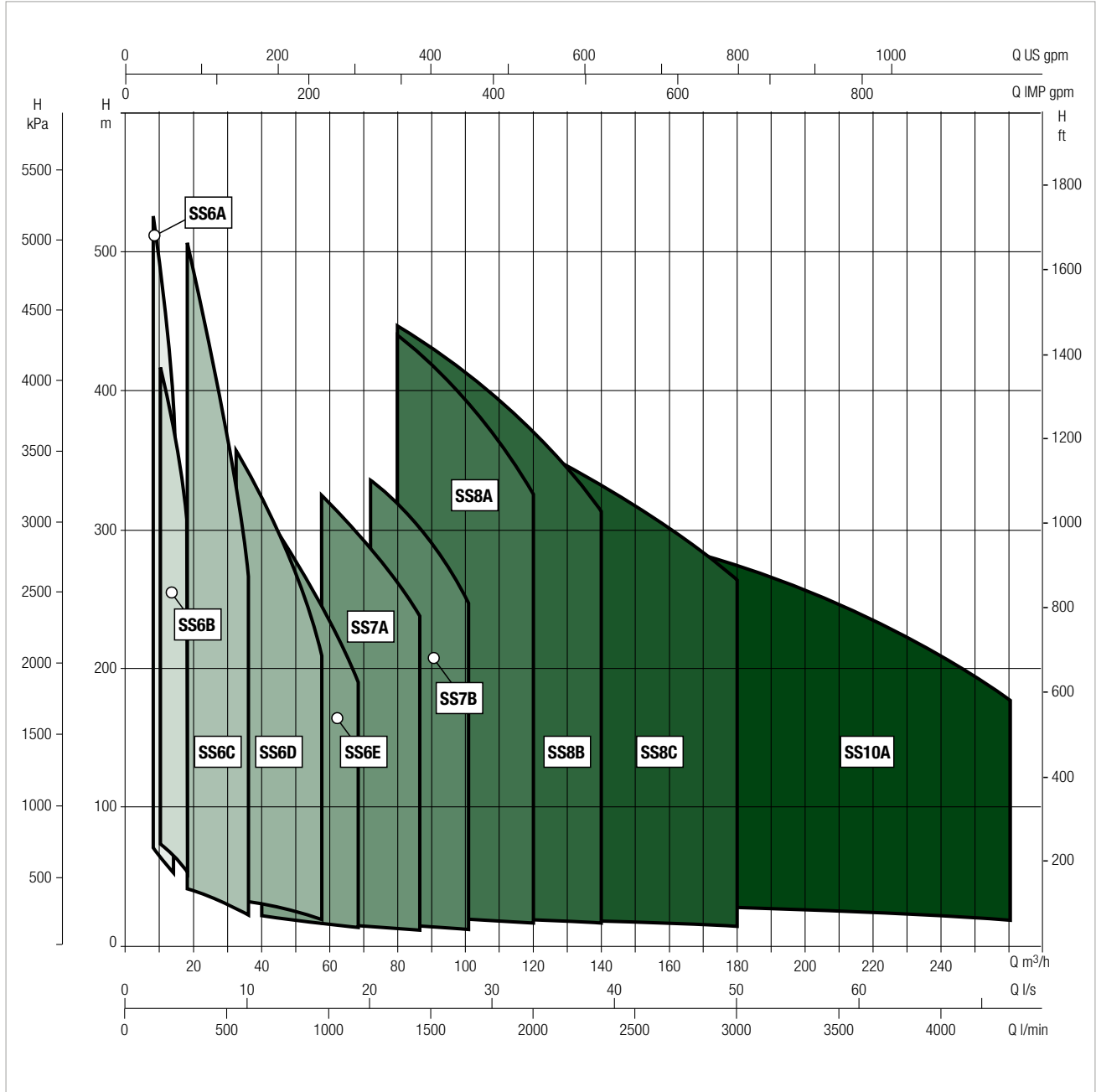

MATERIALS

N.	PARTS	MATERIALS
1	SUCTION CASE	STAINLESS STEEL (AISI 304L)
2	FILTER	STAINLESS STEEL (AISI 304L)
3	SUCTION CASE WEAR RING	BRONZE (ASTM B145-4A)
4	PUMP SHAFT	STAINLESS STEEL (AISI 420)
5	COLLET	STAINLESS STEEL
6	IMPELLER WEAR RING	STAINLESS STEEL (AISI 304)
7	IMPELLER	STAINLESS STEEL (AISI 304L)
8	DIFFUSER	STAINLESS STEEL (AISI 304L)
9	INTERMEDIATE BEARING	RUBBER
10	DIFFUSER WEAR RING	RUBBER
11	NUT FOR STOP RING	STAINLESS STEEL (AISI 304L)
12	BEARING	RUBBER
13	SHAFT STOPPER	BRONZE (ASTM B145-4A)
14	VALVE	STAINLESS STEEL (AISI 304)
15	DISCHARGE CASE	STAINLESS STEEL (AISI 304)
16	TIE ROD	STAINLESS STEEL (AISI 304L)
17	CABLE GUARD	STAINLESS STEEL (AISI 304)
18	TIE ROD NUT	STAINLESS STEEL (AISI 303)
19	NAME PLATE	STAINLESS STEEL (AISI 304)

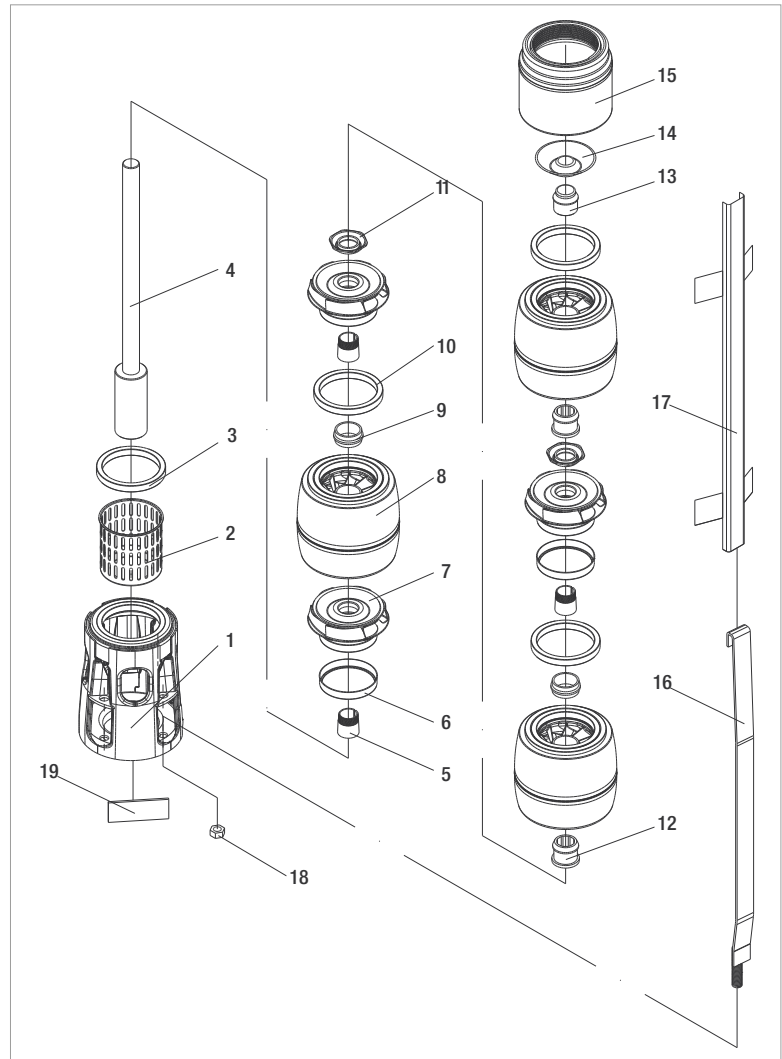

- Denomination index:
(example)

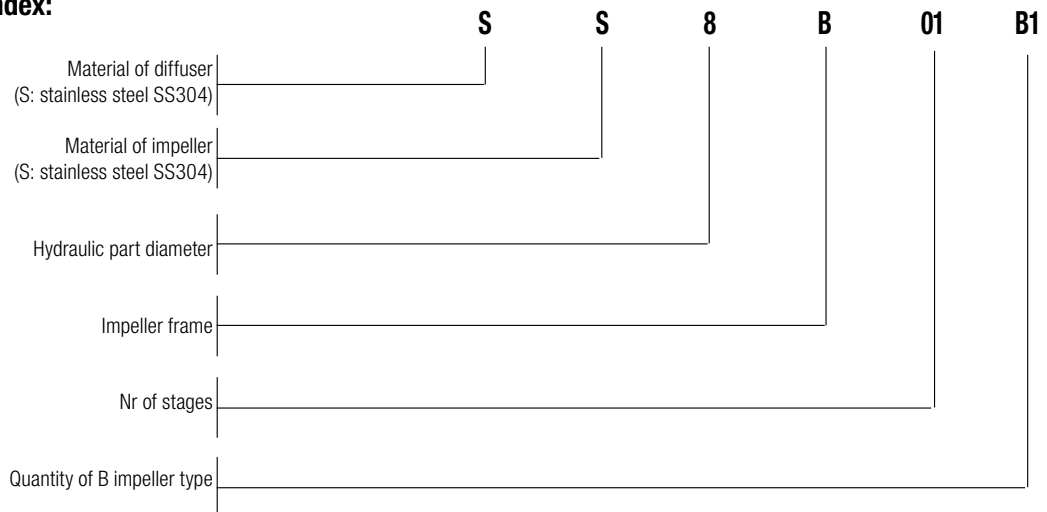

PERFORMANCE 50 Hz - 2 POLES

MODEL	ELECTRICAL DATA		HYDRAULIC DATA											STANDARD MOTOR COUPLING
	P2 NOMINAL		Q=m³/h	0	30	70	80	90	100	110	120	130	140	
	kW	HP	Q=l/min	0	500	1166,6	1333,3	1500	1666,6	1833,3	2000	2166,6	2333,3	
SS8A 01	7,5	10	H (m)	28	26	23	22	21	20	18	16	15	12	6"
SS8A 02	15	20		56	52	46	44	42	39	36	33	29	24	6"
SS8A 03	22	30		83	78	69	66	63	59	54	49	44	37	6"
SS8A 04	30	40		111	104	91	88	83	78	73	66	58	49	6"
SS8A 05	37	50		139	129	114	110	104	98	91	82	73	61	6"
SS8A 06	45	60		167	155	137	131	125	118	109	99	87	73	8"
SS8A 07	55	75		194	181	160	153	146	137	127	115	102	86	8"
SS8A 08	63	85		222	207	183	175	167	157	145	132	116	98	8"
SS8A 09	75	100		250	233	206	197	188	176	163	148	131	110	8"
SS8A 10	75	100		278	259	229	219	208	196	182	165	145	122	8"
SS8A 11	92	125		305	285	252	241	229	216	200	181	160	135	8"
SS8A 12	92	125		333	311	274	263	250	235	218	198	174	147	8"
SS8A 13	92	125		361	337	297	285	271	255	236	214	189	159	8"
SS8A 14	110	150		389	362	320	307	292	274	254	231	203	171	8"
SS8A 15	110	150		416	388	343	329	313	294	272	247	218	184	8"
SS8A 16	132	180		444	414	366	351	333	313	290	264	232	196	10"
SS8A 17	132	180		472	440	389	373	354	333	309	280	247	208	10"
SS8A 18	132	180		500	466	412	394	375	353	327	297	262	220	10"
SS8A 19	147	200		527	492	435	416	396	372	345	313	276	233	10"
SS8A 20	147	200		555	518	457	438	417	392	363	330	291	245	10"

ELECTRICAL DATA AND DIMENSIONS

MODEL	MOTOR *	ELECTRICAL DATA				HORIZONTAL INSTALLATION	L2 mm	L mm	L1 mm	D mm	D1 mm	TOTAL WEIGHT kg
		P2 NOMINAL		In A	OPERATING BY INVERTER							
		kW	HP									
SS8A 01	6GF	7,5	10	18	●	●	1347	661	686	141	213	79
	TR6	7,5	10	18	○	●	1503	817	686	144	213	82
SS8A 02	6GF	15	20	33,4	●	●	1628	786	842	141	213	99
	TR6	15	20	32	○	●	1819	977	842	144	213	115
SS8A 03	6GF	22	30	47	●	●	1918	921	997	141	213	119,3
	TR6	22	30	49	○	●	2064	1067	997	144	213	140
SS8A 04	6GF	30	40	61,5	●	●	2204	1051	1153	141	213	140
	TR6	30	40	65	○	●	2345	1192	1153	144	213	161
SS8A 05	6GF	37	50	79,3	●	●	2490	1181	1309	141	213	159
	TR6	37	50	80	○	●	2601	1292	1309	144	213	170
SS8A 06	TR8	45	60	92	○	●	2735	1270	1465	192	213	241
SS8A 07	TR8	55	75	109	○	●	2970	1350	1620	192	213	262
SS8A 08	TR8	63	85	126	○	●	3266	1490	1776	192	213	294
SS8A 09	TR8	75	100	145	○	●	3522	1590	1932	192	213	320
SS8A 10	TR8	75	100	145	○	●	3677	1590	2087	192	213	326
SS8A 11	TR8	92	125	177	○	●	4073	1830	2243	192	213	378
SS8A 12	TR8	92	125	177	○	●	4229	1830	2399	192	213	384
SS8A 13	TR8	92	125	177	○	●	4384	1830	2554	192	213	391
SS8A 14	TR8	110	150	213	○	●	4770	2060	2710	192	213	447
SS8A 15	TR8	110	150	213	○	●	4926	2060	2866	192	213	453
SS8A 16	TR10	132	180	257	○	●	4892	1870	3022	237	213	562
SS8A 17	TR10	132	180	257	○	●	5047	1870	3177	237	213	568
SS8A 18	TR10	132	180	257	○	●	5203	1870	3333	237	213	574
SS8A 19	TR10	147	200	300	○	●	5559	2070	3489	237	213	645
SS8A 20	TR10	147	200	300	○	●	5714	2070	3644	237	213	652

* 6GF motor: 6" encapsulated water-glycol-filled motor with stator immersed in thermosetting insulating resin
 TR motor: 6-8-10" water-filled rewindable motor.

●	Allowed
○	Only PE2 + PA version

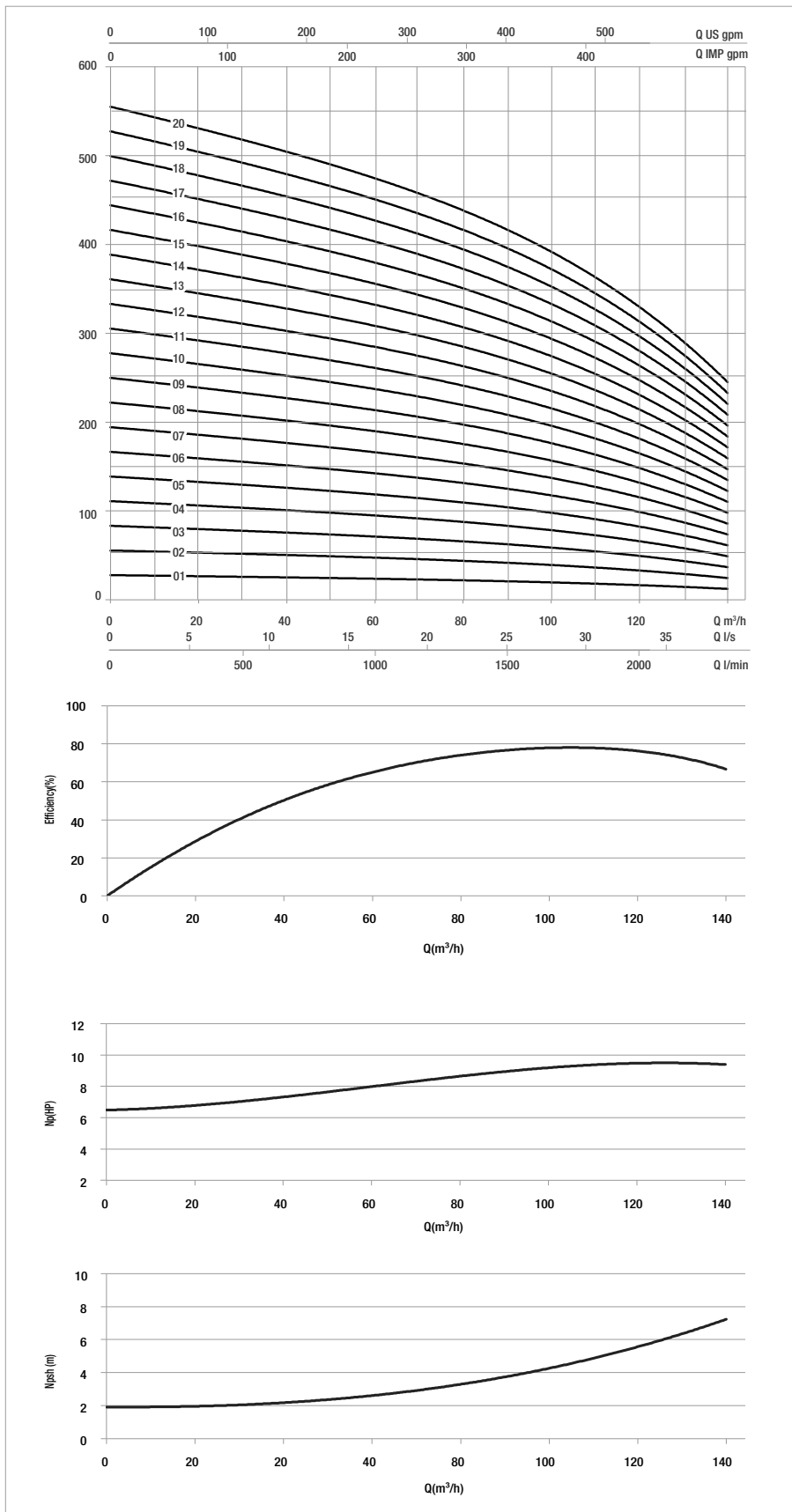
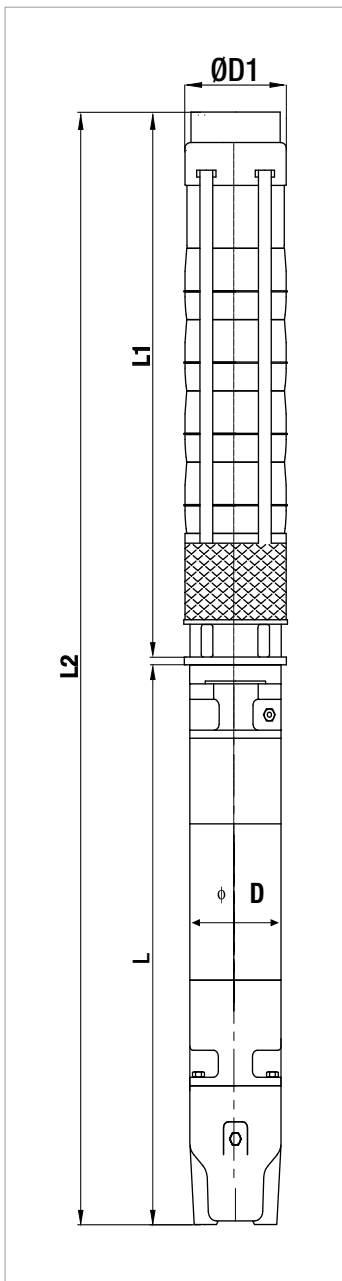

The performance curves are based on the kinematic viscosity values = $1 \text{ mm}^2/\text{s}$ and density equal to $1000 \text{ kg}/\text{m}^3$. Curve tolerance according to ISO 9906.

PERFORMANCE 50 Hz - 2 POLES

MODEL	ELECTRICAL DATA		HYDRAULIC DATA										STANDARD MOTOR COUPLING	
	P2 NOMINAL		Q=m ³ h	0	40	70	90	120	130	140	150	160		170
	kW	HP	Q=l/min	0	666,6	1166,6	1500	2000	2166,6	2333,3	2500	2666,6		2833,3
SS8B 01.B1	9,3	12,5	H (m)	27	25	23	22	19	18	17	16	14	12	6"
SS8B 01	11	15		33	31	28	27	24	23	21	19	17	14	6"
SS8B 02.B2	18,5	25		54	50	46	44	39	37	34	32	28	24	6"
SS8B 02	22	30		65	61	57	53	48	45	42	38	34	29	6"
SS8B 03.B3	30	40		80	75	70	66	58	55	52	47	42	35	6"
SS8B 03	37	50		98	92	85	80	71	68	63	58	51	43	6"
SS8B 04	45	60		131	122	113	107	95	90	84	77	68	58	8"
SS8B 05.B3	55	75		146	136	126	119	106	100	94	86	76	64	8"
SS8B 05	55	75		163	153	142	134	119	113	105	96	85	72	8"
SS8B 06	75	100		196	183	170	160	143	135	126	115	102	87	8"
SS8B 07	75	100		228	214	198	187	166	158	147	135	119	101	8"
SS8B 08	92	125		261	245	227	214	190	180	168	154	136	115	8"
SS8B 09	110	150		294	275	255	240	214	203	189	173	153	130	8"
SS8B 10	110	150	326	306	283	267	238	225	210	192	171	144	8"	
SS8B 11	132	180	359	336	312	294	261	248	231	211	188	159	10"	
SS8B 12	132	180	392	367	340	320	285	270	252	231	205	173	10"	
SS8B 13	147	200	424	397	368	347	309	293	273	250	222	187	10"	

ELECTRICAL DATA AND DIMENSIONS

MODEL	MOTOR *	ELECTRICAL DATA				HORIZONTAL INSTALLATION	L2 mm	L mm	L1 mm	D mm	D1 mm	TOTAL WEIGHT kg
		P2 NOMINAL		In A	OPERATING BY INVERTER							
		kW	HP									
SS8B 01.B1	6GF	9,3	12,5	22	●	●	1372	686	686	141	213	82
	TR6	9,3	12,5	21	○	●	1533	847	686	144	213	87
SS8B 01	6GF	11	15	25,5	●	●	1417	731	686	141	213	87
	TR6	11	15	25	○	●	1563	877	686	144	213	92
SS8B 02.B2	6GF	18,5	25	41	●	●	1703	861	842	141	213	108
	TR6	18,5	25	39	○	●	1879	1037	842	144	213	119
SS8B 02	6GF	22	30	47	●	●	1763	921	842	141	213	113,3
	TR6	22	30	49	○	●	1909	1067	842	144	213	134
SS8B 03.B3	6GF	30	40	61,5	●	●	2048	1051	997	141	213	134
	TR6	30	40	65	○	●	2189	1192	997	144	213	155
SS8B 03	6GF	37	50	79,3	●	●	2178	1181	997	141	213	147
	TR6	37	50	80	○	●	2289	1292	997	144	213	158
SS8B 04	TR8	45	60	92	○	●	2423	1270	1153	192	213	229
SS8B 05.B3	TR8	55	75	109	○	●	2659	1350	1309	192	213	250
SS8B 05	TR8	55	75	109	○	●	2659	1350	1309	192	213	250
SS8B 06	TR8	75	100	145	○	●	3055	1590	1465	192	213	302
SS8B 07	TR8	75	100	145	○	●	3210	1590	1620	192	213	308
SS8B 08	TR8	92	125	177	○	●	3606	1830	1776	192	213	361
SS8B 09	TR8	110	150	213	○	●	3992	2060	1932	192	213	417
SS8B 10	TR8	110	150	213	○	●	4147	2060	2087	192	213	424
SS8B 11	TR10	132	180	257	○	●	4113	1870	2243	237	213	532
SS8B 12	TR10	132	180	257	○	●	4269	1870	2399	237	213	539
SS8B 13	TR10	147	200	300	○	●	4624	2070	2554	237	213	610

* **6GF motor:** 6" encapsulated water-glycol-filled motor with stator immersed in thermosetting insulating resin
TR motor: 6-8-10" water-filled rewindable motor.

●	Allowed
○	Only PE2 + PA version

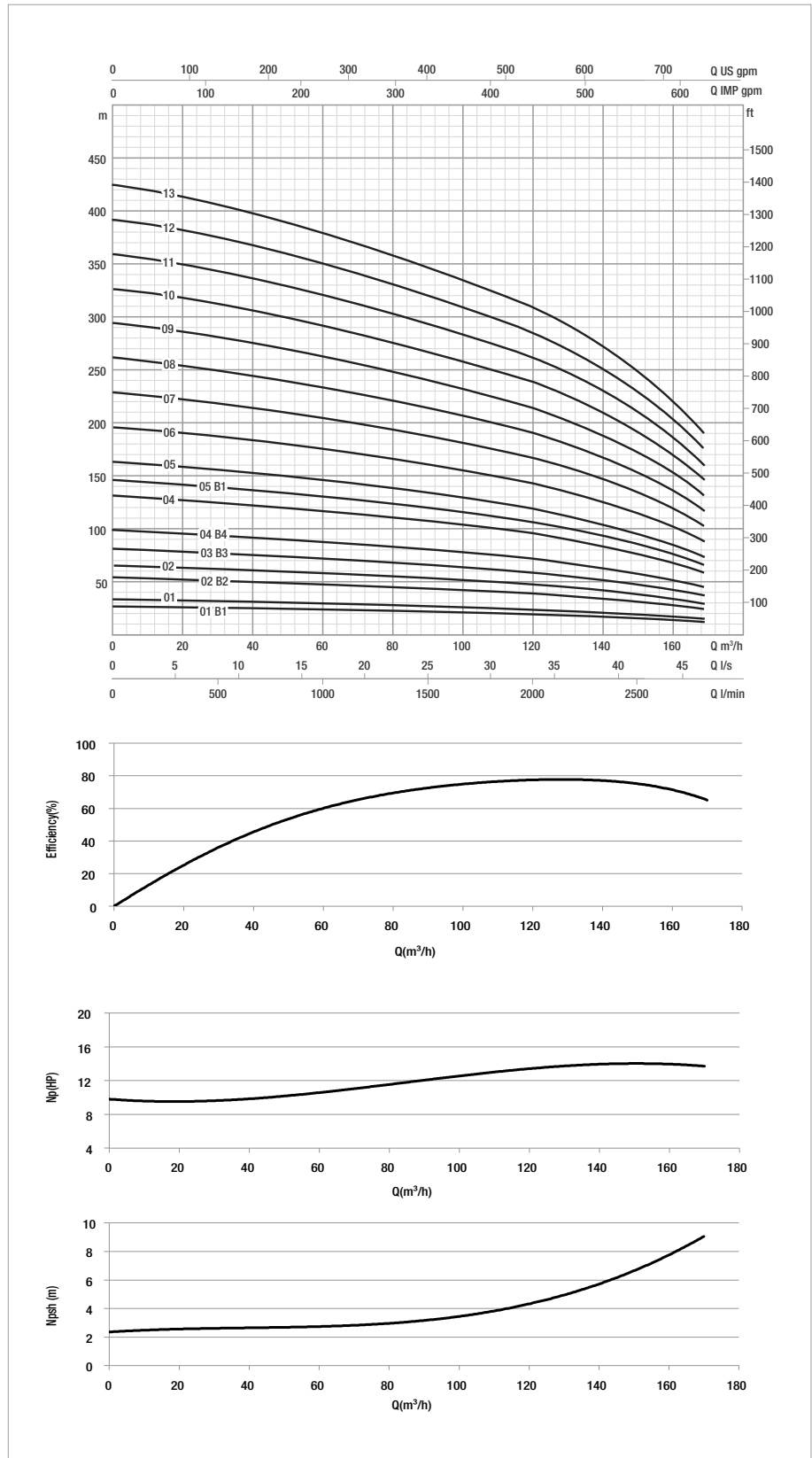
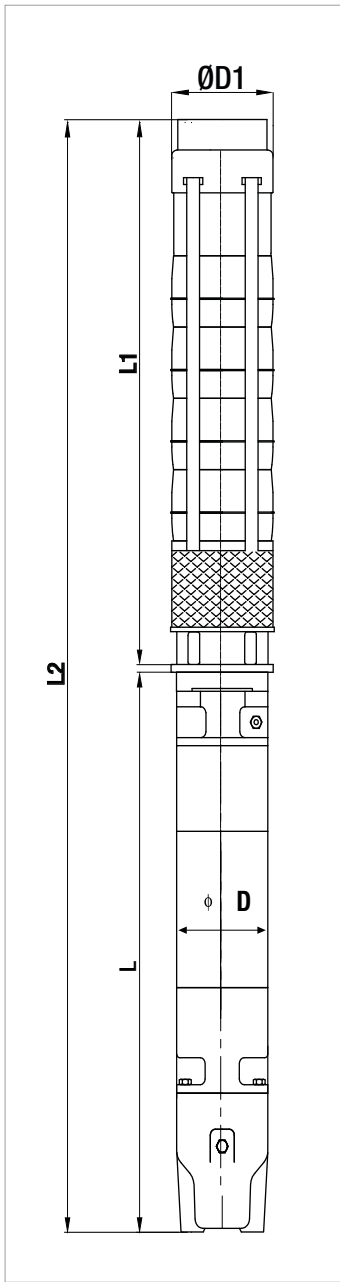

The performance curves are based on the kinematic viscosity values = 1 mm²/s and density equal to 1000 kg/m³. Curve tolerance according to ISO 9906.

PERFORMANCE 50 Hz - 2 POLES

MODEL	ELECTRICAL DATA		HYDRAULIC DATA										STANDARD MOTOR COUPLING	
	P2 NOMINAL		Q=m ³ h	0	50	70	90	110	130	150	170	190		210
	kW	HP	Q=l/min	0	833,3	1166,6	1500	1833,3	2166,6	2500	2833,3	3166,6		3500
SS8C 01.B1	9,3	12,5	H (m)	24	22	21	20	18	17	16	14	12	9	6"
SS8C 01	11	15		30	28	26	24	23	22	20	18	15	11	6"
SS8C 02.B2	18,5	25		48	44	42	39	37	34	32	28	23	17	6"
SS8C 02	22	30		60	55	52	49	26	43	40	35	29	22	6"
SS8C 03.B3	30	40		78	72	68	64	60	56	52	46	38	28	6"
SS8C 03	37	50		90	83	78	73	69	65	60	53	44	32	6"
SS8C 04	45	60		120	111	104	98	92	86	80	71	58	43	8"
SS8C 05	55	75		150	139	130	122	115	108	99	88	73	54	8"
SS8C 06.B3	63	85		162	150	141	132	124	116	107	95	79	58	8"
SS8C 06	75	100		180	166	156	147	138	129	119	106	88	65	8"
SS8C 07.B3	75	100		192	177	167	156	147	138	127	113	94	69	8"
SS8C 07	92	125		210	194	182	171	161	151	139	124	102	76	8"
SS8C 08	92	125		240	222	208	195	184	172	159	141	117	87	8"
SS8C 09	110	150		270	249	234	220	207	194	179	159	132	97	8"
SS8C 10	110	150		300	277	260	244	230	215	199	176	146	108	8"
SS8C 11	132	180		330	305	286	269	253	237	219	194	161	119	10"
SS8C 12	147	200	360	333	312	293	276	259	239	212	175	130	10"	
SS8C 13	147	200	390	360	338	318	299	280	258	229	190	141	10"	
SS8C 14	170	230	420	388	364	342	322	302	278	247	205	152	10"	
SS8C 15	190	260	450	416	390	366	345	323	298	265	219	162	10"	
SS8C 16	190	260	480	443	416	391	368	345	318	282	234	173	10"	

ELECTRICAL DATA AND DIMENSIONS

MODEL	MOTOR *	ELECTRICAL DATA				HORIZONTAL INSTALLATION	L2 mm	L mm	L1 mm	D mm	D1 mm	TOTAL WEIGHT kg
		P2 NOMINAL		In A	OPERATING BY INVERTER							
		kW	HP									
SS8C 01.B1	6GF	9,3	12,5	22	●	●	1372	686	686	141	226	84
	TR6	9,3	12,5	21	○	●	1533	847	686	144	226	89
SS8C 01	6GF	11	15	25,5	●	●	1417	731	686	141	226	89
	TR6	11	15	25	○	●	1563	877	686	144	226	94
SS8C 02.B2	6GF	18,5	25	41	●	●	1703	861	842	141	226	109
	TR6	18,5	25	39	○	●	1879	1037	842	144	226	120
SS8C 02	6GF	22	30	47	●	●	1763	921	842	141	226	114,3
	TR6	22	30	49	○	●	1909	1067	842	144	226	135
SS8C 03.B3	6GF	30	40	61,5	●	●	2048	1051	997	141	226	136
	TR6	30	40	65	○	●	2189	1192	997	144	226	157
SS8C 03	6GF	37	50	79,3	●	●	2178	1181	997	141	226	149
	TR6	37	50	80	○	●	2289	1292	997	144	226	160
SS8C 04	TR8	45	60	92	○	●	2423	1270	1153	192	226	230
SS8C 05	TR8	55	75	109	○	●	2659	1350	1309	192	226	252
SS8C 06.B3	TR8	63	85	126	○	●	2955	1490	1465	192	226	284
SS8C 06	TR8	75	100	145	○	●	3055	1590	1465	192	226	303
SS8C 07.B3	TR8	75	100	145	○	●	3210	1590	1620	192	226	310
SS8C 07	TR8	92	125	177	○	●	3450	1830	1620	192	226	356
SS8C 08	TR8	92	125	177	○	●	3606	1830	1776	192	226	362
SS8C 09	TR8	110	150	213	○	●	3992	2060	1932	192	226	419
SS8C 10	TR8	110	150	213	○	●	4147	2060	2087	192	226	425
SS8C 11	TR10	132	180	257	○	●	4113	1870	2243	237	226	534
SS8C 12	TR10	147	200	300	○	●	4469	2070	2399	237	226	605
SS8C 13	TR10	147	200	300	○	●	4624	2070	2554	237	226	612
SS8C 14	TR10	170	230	348	○	●	4930	2220	2710	237	226	658
SS8C 15	TR10	190	260	405	○	●	5266	2400	2866	237	226	704
SS8C 16	TR10	190	260	405	○	●	5422	2400	3022	237	226	711

* 6GF motor: 6" encapsulated water-glycol-filled motor with stator immersed in thermosetting insulating resin
 TR motor: 6-8-10" water-filled rewindable motor.

●	Allowed
○	Only PE2 + PA version

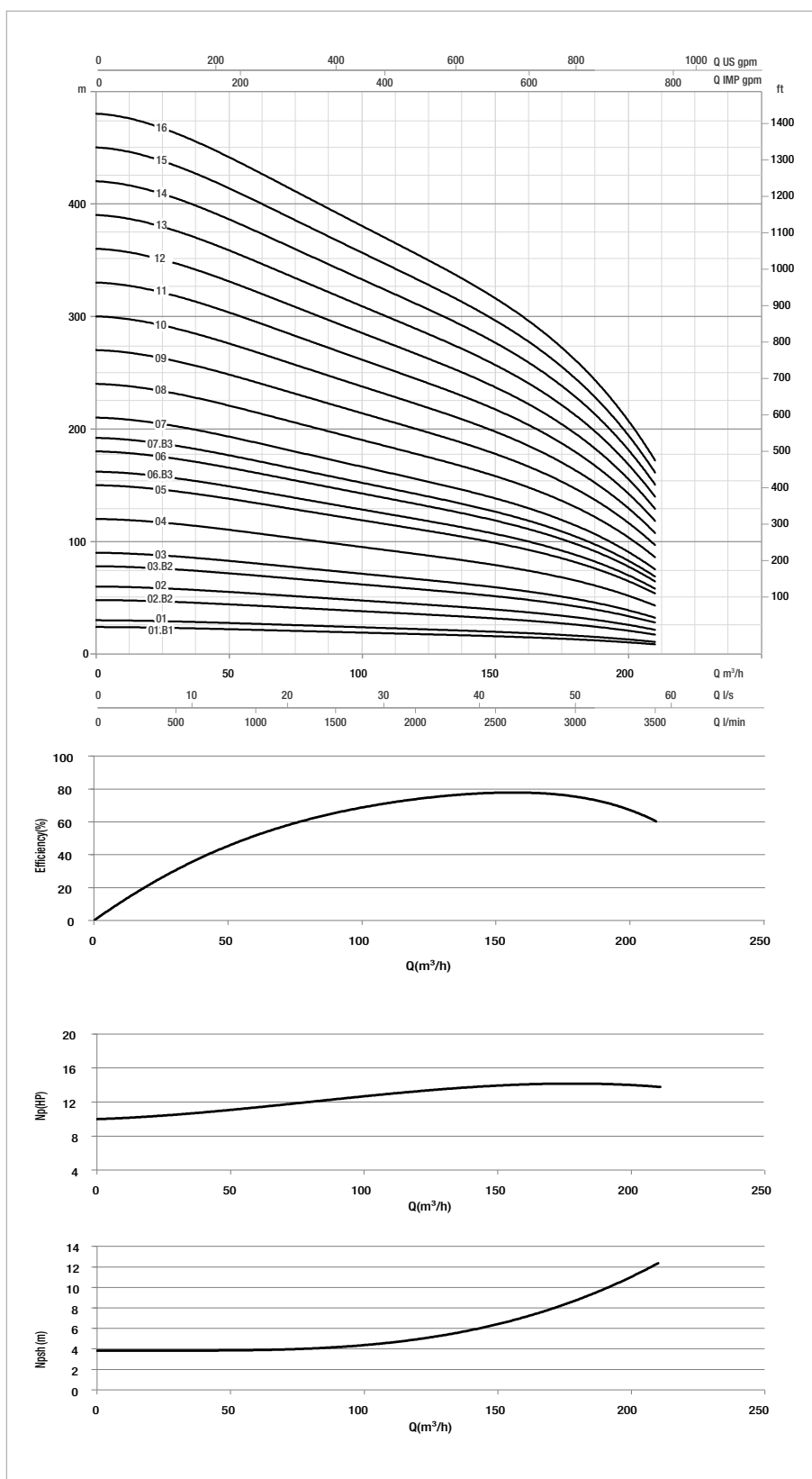
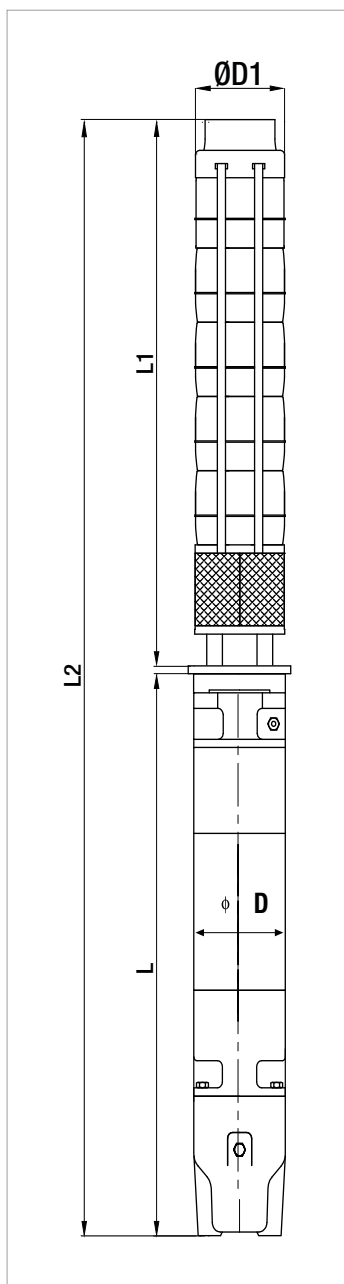

The performance curves are based on the kinematic viscosity values = 1 mm²/s and density equal to 1000 kg/m³. Curve tolerance according to ISO 9906.