

GAMA CON PREFILTRO

BOMBAS CENTRÍFUGAS NORMALIZADAS MONOBLOCK CON PREFILTRO DE FUNDICIÓN



PREFILTRO



PREFILTRO + BOMBA

Gama de prefiltros de fundición en línea con la norma DIN 2501, de DN 65 a DN 200. Provisto de 3 o 4 pernos de cierre en función del modelo para asegurar un perfecto sellado de la tapa. Prefiltro y tapa de hierro fundido, cesta en acero inoxidable AISI 316. La gama de prefiltros permite el uso de bombas centrífugas monoblock serie NKM-G, NKP-G, de DN 40 a DN 150, para la circulación de agua en sistemas de filtración de gran tamaño. Los mismos prefiltros pueden ser utilizados con bombas normalizadas sobre bancada (KDN) o con variador de velocidad MCE.

Electrobombas centrífugas monoblock con acoplamiento a las que se les añade un prefiltro en la aspiración para la circulación de agua en grandes sistemas de filtración (agua con cloro o salada). **La bomba y el prefiltro se venden por separado.**

Cuerpo en espiral monoturbina de fundición en línea con la norma DIN-EN 733 (ex DIN2455), soporte de hierro fundido, bridas según norma DIN 2533. Turbina de fundición de hierro, bronce versión TOP, cerrada y equilibrada dinámicamente con compensación del empuje axial mediante agujeros de equilibrio. Cierre mecánico BAQV, carbón/carburo de silicio con juntas OR de Vitón. Eje de acero inoxidable AISI 304.

Motor asincrónico hermético con ventilación externa, forma constructiva B3/B5, de 2 polos para NKP-G y de 4 polos para NKM-G.

Velocidad de rotación 1450-2900 1/min

Rango de funcionamiento

de 1 a 440 m³/h con altura de elevación de hasta 24 metros.

Líquido bombeado limpio o ligeramente sucio o ligeramente agresivo, siempre que se compruebe la compatibilidad de los materiales de fabricación de la bomba y que la potencia del motor instalado sea adecuada al peso específico y a la viscosidad del líquido.

Rango temperatura del líquido

de -10 °C a +140 °C

Temperatura ambiente máxima +40°C

Instalación en posición horizontal

Versión TOP

rodete de bronce y tratamiento de cataforesis

MOTORES TRIFÁSICOS	P2	< 0,75 kW	IE2
		≥ 0,75 kW < 75 kW	IE3
		≥ 75 kW	IE4*

NKM-G 4 POLOS 1450 l/min

MODELO	DNA	DNM	DATOS ELÉCTRICOS				DATOS HIDRÁULICOS									
			ALIMENT. 50 Hz	P2 NOM.		In A		m ³ /h l/min	0	6	12	18	24	30	36	42
				kW	HP	230V	400V		0	100	200	300	400	500	600	700
NKM-G 40-200/200/ 1,1 /4	65	40	3x230-400V	1.1	1.5	4,68	2,7	H (m)	12.5	12.5	12.3	11.2	9.7	7.7		
NKM-G 40-200/219/ 1,5 /4	65	40	3x230-400V	1.5	2	6,24	3,6		15.6	15.6	15.3	14.7	13.4	11.8	9.8	
NKM-G 40-250/245/ 2,2 /4	65	40	3x230-400V	2.2	3	8,75	5,05		20.6	20.5	20.1	19.2	17.8	16		

MODELO	DNA	DNM	DATOS ELÉCTRICOS				DATOS HIDRÁULICOS											
			ALIMENT. 50 Hz	P2 NOM.		In A		m ³ /h l/min	0	12	18	24	30	36	42	48	54	60
				kW	HP	230V	400V		0	200	300	400	500	600	700	800	900	1000
NKM-G 50-160/177/ 1,5 /4	65	50	3x230-400V	1.5	2	6,24	3,6	H (m)	10.7	10.7	10.7	10.5	10.2	9.8	9.2	8.3		
NKM-G 50-200/210/ 2,2 /4	65	50	3x230-400V	2.2	3	8,75	5,05		15.3	15.3	15.2	14.8	14	13.3	12.1	10.8	9.4	
NKM-G 50-200/219/ 3 /4	65	50	3x400 V Δ	3	4	-	6,25		16.8	16.8	16.5	16.1	15.5	14.6	13.6	12.4	10.9	
NKM-G 50-250/263/ 4 /4	65	50	3x400 V Δ	4	5.5	-	7,95		23.8	23.8	23.8	23.4	22.7	21.6	20.4	19	17.1	

MODELO	DNA	DNM	DATOS ELÉCTRICOS				DATOS HIDRÁULICOS											
			ALIMENT. 50 Hz	P2 NOM.		In A 400V	m ³ /h l/min	0	24	30	36	42	48	54	60	66	72	78
				kW	HP			0	400	500	600	700	800	900	1000	1100	1200	1300
NKM-G 65-200/210/ 3 /4	80	65	3x400 V Δ	3	4	6,25	H (m)	15.3	15.2	15.2	15.1	14.6	14.1	13.5	12.9	12.2	11.3	
NKM-G 65-200/219/ 4 /4	80	65	3x400 V Δ	4	5.5	7,95		17	17	16.9	16.8	16.4	16.2	15.8	15.2	14.3	13.8	12.6
NKM-G 65-250/263/ 5,5 /4	80	65	3x400 V Δ	5.5	7.5	10,6		24.1	23.8	23.6	23.3	22.8	22.3	21.5	20.8	19.7	18.6	17.3

MODELO	DNA	DNM	DATOS ELÉCTRICOS				DATOS HIDRÁULICOS													
			ALIMENT. 50 Hz	P2 NOM.		In A 400V	m ³ /h l/min	0	42	48	54	60	66	72	78	84	90	102	114	120
				kW	HP			0	700	800	900	1000	1100	1200	1300	1400	1500	1700	1900	2000
NKM-G 80-200/200/ 4 /4	100	80	3x400 V Δ	4	5.5	7,95	H (m)	13.2	13.1	13	12.9	12.8	12.7	12.4	12	11.7	11.3	10.4	9.3	8.7
NKM-G 80-200/222/ 5,5 /4	100	80	3x400 V Δ	5.5	7.5	10,6		16.6	16.5	16.5	16.4	16.2	16.1	16	15.7	15.4	15	14.3	13.3	12.7
NKM-G 80-250/240/ 7,5 /4	100	80	3x400 V Δ	7.5	10	14,6		20.4	20.3	20.3	20.2	20.1	20	19.9	19.8	19.5	19	18	16.7	16
NKM-G 80-250/270/11 /4	100	80	3x400 V Δ	11	15	20,5		25.6	25.5	25.5	25.4	25.1	25	24.8	24.6	24.2	24	23	21.5	21

GAMA CON PREFILTRO

BOMBAS CENTRÍFUGAS NORMALIZADAS MONOBLOCK CON PREFILTRO DE FUNDICIÓN



MODELO	DNA	DNM	DATOS ELÉCTRICOS			DATOS HIDRÁULICOS															
			ALIMENT. 50 Hz	P2 NOM.		In A 400V	m³/h l/min	0	60	66	72	78	84	90	102	114	120	150	180	210	
				kW	HP			0	1000	1100	1200	1300	1400	1500	1700	1900	2000	2500	3000	3500	
NKM-G100-200/200/ 5.5 /4	125	100	3x400 V Δ	5.5	7.5	10.6	H (m)	12.7	12.6	12.6	12.5	12.5	12.4	12.3	12	11.5	11.4	10.1	8.5		
NKM-G100-200/214/ 7.5 /4	125	100	3x400 V Δ	7.5	10	14.6		15.6	15.4	15.4	15.3	15.2	15.1	15	14.7	14.5	14.3	13.3	11.6	9.8	
NKM-G100-250/250/11 /4	125	100	3x400 V Δ	11	15	20.5		21.1	21	21	21	21	21	21	20.9	20	19.8	18	16		

MODELO	DNA	DNM	DATOS ELÉCTRICOS			DATOS HIDRÁULICOS																
			ALIMENT. 50 Hz	P2 NOM.		In A 400V	m³/h l/min	0	102	114	120	150	180	210	240	270	300	330	360	390	420	
				kW	HP			0	1700	1900	2000	2500	3000	3500	4000	4500	5000	5500	6000	6500	7000	
NKM-G125-250/243/15 /4	150	125	3x400 V Δ	15	20	28	H (m)	19.5	19.3	19.3	19.2	19.2	18.7	17.8	16.8	15.5	14.1	12.5	10.9			
NKM-G125-250/256/18,5 /4	150	125	3x400 V Δ	18.5	25	34		21.9	21.8	21.8	21.7	21.6	21.3	20.5	19.5	18.5	17.2	15.6	14	12		
NKM-G150-200/218/11 /4	200	150	3x400 V Δ	11	15	20.5		13.2	13.1	13	13	12.8	12.5	12.1	11.5	11	10.4	9.7	9	8	7	

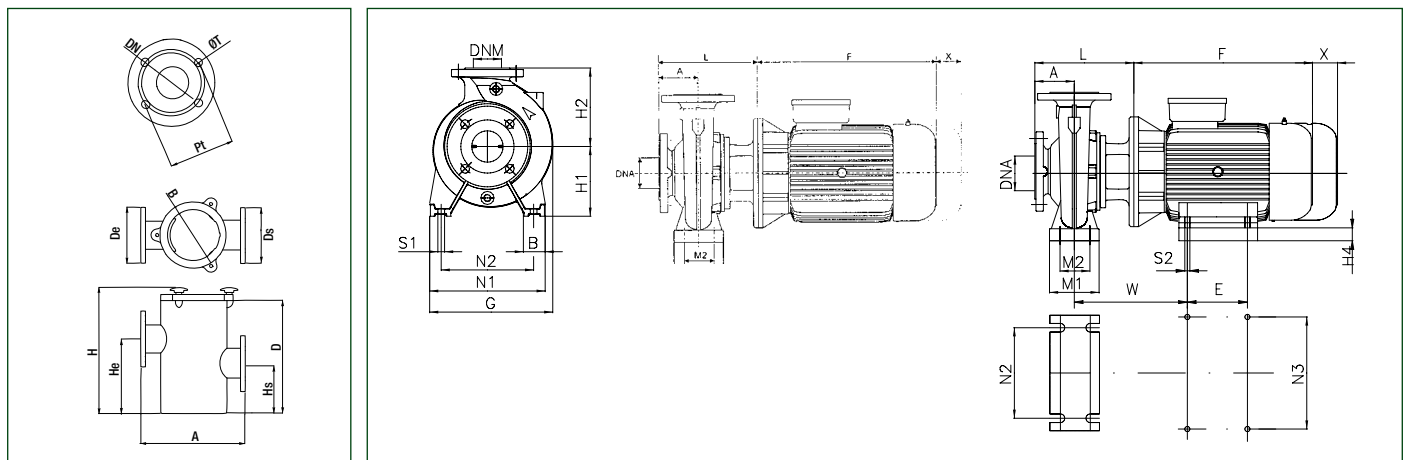

TIPO	DN	Pt	A	B	H	D	De	He	Ds	Hs	øT	N°T	Kg	VOLUMEN litros
PRE FILTRO 65/65	65	145	380	260	415	360	185	250	185	120	18	4	38,5	18
PRE FILTRO 80/80	80	160	380	260	415	360	200	250	200	120	18	4-8	39	18
PRE FILTRO 100/100	100	180	380	260	415	360	200	270	220	155	18	8	40,5	18
PRE FILTRO 125/125	125	210	380	260	415	360	250	270	250	155	18	8	41	18
PRE FILTRO 150/150	150	240	460	340	555	500	285	380	285	190	22	8	71	42
PRE FILTRO 200/200	200	295	460	340	555	500	340	380	340	190	22	8	72	42

MODELO	A	B	E	F (min)	G	H1	H2	L	M1	M2	N1	N2	N3	S1	S2	W	X	H4	Ø CIERRE	DNA	DNM	DIMENSIONES EMBALAJE			VOL. m³	PESO Kg
																						L/A	L/B	H		
NKM-G40-200/200/1,1/4	100	50	-	287,5	296	160	180	246	100	70	265	212	-	M10	-	-	100	-	28	65	40	620	370	480	0,11	41
NKM-G40-200/219/1,5/4	100	50	-	287,5	296	160	180	246	100	70	265	212	-	M10	-	-	100	-	28	65	40	620	370	480	0,11	42
NKM-G40-250/245/2,2/4	100	65	-	319	336	180	225	274	125	95	320	250	-	M10	-	-	100	-	28	65	40	670	420	540	0,152	63
NKM-G50-160/177/1,5/4	100	50	-	287,5	282	160	180	274	100	70	265	212	-	M10	-	-	100	-	28	65	50	620	370	480	0,11	35
NKM-G50-200/210/2,2/4	100	50	-	319	302	160	200	274	100	70	265	212	-	M10	-	-	100	-	28	65	50	670	420	540	0,152	55
NKM-G50-200/219/3/4	100	50	-	321	302	160	200	274	100	70	265	212	-	M10	-	-	100	-	28	65	50	670	420	540	0,152	52
NKM-G50-250/263/4/4	100	65	-	328	343	180	225	274	125	95	320	250	-	M10	-	-	100	-	28	65	50	670	420	540	0,152	56
NKM-G65-200/210/3/4	100	65	-	321	333	180	225	274	125	95	320	250	-	M10	-	-	140	-	28	80	65	670	420	540	0,152	56
NKM-G65-200/219/4/4	100	65	-	328	333	180	225	274	125	95	320	250	-	M10	-	-	140	-	28	80	65	670	420	540	0,152	58
NKM-G65-250/263/5,5/4	100	80	-	365	370	200	250	343	160	120	360	280	-	M14	-	-	140	-	38	80	65	1030	530	640	0,349	142
NKM-G80-200/200/4/4	125	65	-	328	365	180	250	368	125	95	345	280	-	M10	-	-	140	-	38	100	80	1030	530	640	0,349	84
NKM-G80-200/222/5,5/4	125	65	-	365	365	180	250	368	125	95	345	280	-	M10	-	-	140	-	38	100	80	1030	530	640	0,349	130
NKM-G80-250/240/7,5/4	125	80	-	350	410	200	280	368	160	120	400	315	-	M14	-	-	140	-	38	100	80	1030	530	640	0,349	153
NKM-G80-250/270/11/4	125	80	210	498	410	200	280	398	160	120	400	315	254	M14	M12	381	140	40	38	100	80	1030	530	640	0,349	205
NKM-G100-200/200/5,5/4	125	80	-	365	392	200	280	368	160	120	360	280	-	M14	-	-	140	-	38	125	100	1030	530	640	0,349	142
NKM-G100-200/214/7,5/4	125	80	-	350	392	200	280	368	160	120	360	280	-	M14	-	-	140	-	38	125	100	1030	530	640	0,349	149
NKM-G100-250/250/11/4	140	80	210	498	424	225	280	413	160	120	400	315	254	M14	M12	381	140	65	38	125	100	1030	530	640	0,349	213
NKM-G125-250/243/15/4	140	80	254	542	472	250	355	413	160	120	400	315	254	M14	M12	381	140	90	38	150	125	1130	580	740	0,485	274
NKM-G125-250/256/18,5/4	140	80	241	577	472	250	355	413	160	120	400	315	279	M14	M12	394	140	70	38	150	125	1130	580	740	0,485	290
NKM-G150-200/218/11/4	160	100	210	498	593	280	400	433	200	150	550	450	254	M20	-	381	140	120	38	200	150	1130	650	900	0,661	280

GAMA CON PREFILTRO

BOMBAS CENTRÍFUGAS NORMALIZADAS MONOBLOCK CON PREFILTRO DE FUNDICIÓN



TABLA DE SELECCIÓN = BOMBA + FILTRO + KIT DE FIJACIÓN

POLOS		TIPO DE BOMBA			PREFILTRO		KIT DE FIJACIÓN FILTRO-BOMBA	
2	4	MODELO	CÓDIGO VERSIÓN BASE	CÓDIGO VERSIÓN TOP	MODELO	CÓDIGO	MODELO	CÓDIGO
	•	NKM-G40-200/200/1,1/4	1D2317B4W	60180148	PREFILTRO 65/65 38,5 Kg - 18 Litros	60164699	KIT FIJACIÓN PREFILTRO DN 65	60166309
	•	NKM-G40-200/219/1,5/4	1D2317B5W	60180149				
	•	NKM-G40-250/245/2,2/4	1D2417B6W	60180150				
	•	NKM-G50-160/177/1,5 /4	1D3217B5W	60180151				
	•	NKM-G50-200/210/2,2/4	1D3317B6W	60180152				
	•	NKM-G50-200/219/3/4	1D3317B7X	60180153				
	•	NKM-G50-250/263/4/4	1D3417B8X	60180154				
	•	NKP-G 40-125/107/1,5/2	1D2117B5U	60180161				
	•	NKP-G 40-125/120/2,2/2	1D2117B6U	60180162				
	•	NKP-G 40-125/130/3/2	1D2117B7V	60180163				
	•	NKP-G 50-125/115/3/2	1D3117B7V	60180164				
	•	NKP-G 50-125/125/4/2	1D3117B8V	60180165				
	•	NKP-G 50-125/135/5,5/2	1D3117B9V	60180166				
	•	NKM-G65-200/210/3/4	1D4317B7X	60180155	PREFILTRO 80/80 39 Kg - 18 Litros	60164700	KIT FIJACIÓN PREFILTRO DN 80-100-125	60166312
	•	NKM-G65-200/219/4/4	1D4317B8X	60180156				
	•	NKM-G65-250/263/5,5/4	1D4417B9X	60180157				
	•	NKP-G 65-125/120-110/4/2	1D4117B8V	60180167				
	•	NKP-G 65-125/127/5,5/2	1D4117B9V	60180168				
	•	NKP-G 65-125/137/7,5/2	1D4117BAV	60168378				
	•	NKM-G80-200/200/4/4	1D5317B8X	60180158	PREFILTRO 100/100 40,5 Kg - 18 Litros	60164701	KIT FIJACIÓN PREFILTRO DN 80-100-125	60166312
	•	NKM-G80-200/222/5,5/4	1D5317B9X	60180159				
	•	NKM-G80-250/240/7,5/4	1D5417BAX	60168350				
	•	NKM-G80-250/270/11/4	1D5417BBX	60168351				
	•	NKP-G 80-160/147-127/11/2	1D5217BBV	60168379				
	•	NKM-G100-200/200/ 5,5/4	1D6317B9X	60180160	PREFILTRO 125/125 41 Kg - 18 Litros	60164702	KIT FIJACIÓN PREFILTRO DN 80-100-125	60166312
	•	NKM-G100-200/214/ 7,5/4	1D6317BAX	60168353				
	•	NKM-G100-250/250/11 /4	1D6417BBX	60168369				
	•	NKM-G125-250/243/15/4	1D7417BCX	60168370	PREFILTRO 150/150 71 Kg - 42 Litros	60164703	KIT FIJACIÓN PREFILTRO DN150-200	60166313
	•	NKM-G125-250/256/18,5/4	1D7417BDX	60168371				
	•	NKM-G150-200/218/11/4	1D8317BBX	60168376	PREFILTRO 200/200 72 Kg - 42 Litros	60164704	KIT FIJACIÓN PREFILTRO DN150-200	60166313

Versión TOP: rodete de bronce y tratamiento de cataforesis.

